



Tailor-made protective systems for
Transport & Logistics



Tailor-made. Experience gained by 25 years of success.

Logistic systems and carrying cases have to work in every case. They have a function. If this is fulfilled the products are of good quality. It's that simple or that difficult.

To develop a healthy understanding regarding what is possible in order to fulfill the expectations of the market is the pre-condition. All in all KKC's product designing shows a wide range of high class logistic systems and transport packaging. Individual solutions complete the standard program of KKC.

We have chosen the right path. Our solid growing team which reflects our sales figures, the ever increasing degree of awareness of the high profile brand name "KKC" as synonym for quality, willingness to perform and reliability all show this.



Innovative. For every branch and every use.

To be able to offer protection and packaging for all transport routes causes permanent challenging of requirement profiles.

On the one hand KKC transport solutions should be at good value and on the other hand they should be the right solution for every intended use. The balancing act between requirements and possibilities, wishful thinking and reality.

The market says: KKC has succeeded.



Successful. As a valued customer of KKC, be assured, you are in excellent company.

The fact that others have chosen KKC says it all ...
... it's that simple. We believe that the quality of our services is best reflected in the evaluation of our customers.

Therefore our top priority is your satisfaction resulting in us becoming long-term business partners.

KKC's best reference is their long standing business relationships with prominent companies such as Robert Bosch, Bosch-Siemens-Household appliances, Buderus-Heating systems, Deutsche Telekom (German Telecommunication), Christian Dior, Fujitsu-Siemens Computer, Gardena, HBM, Kraft-Jacobs, LVM-Insurance company, Philips AG, Trumpf engineering, Weinmann, WMF, Siemens and above all: you.



Ambitious. Our modern, well-structured production.

Our high rate of efficiency is achieved due to production technology of our own design. Sophisticated machines standardise and duplicate procedures. Individual craftsmanship by hand is always used when highest accuracy and an expert eye are needed to result in that extra degree of quality and service.



Motivated. Quality, security and perfection.

KKC logistic systems and transport packaging, for the most part, are hand-made. Therefore optimal project preparation along with the employees' motivation and identification with the company's philosophy and products are crucial factors.

KKC's employees' attitude is fixed on quality and as a

result they assume personal responsibility for achieving and maintaining the company's high standard for production and quality control.

Why? Because we want your next order.



Motivated. Delivery readiness and capabilities.

KKC cases Ltd., in addition to its modern production facility, has the capability of responding rapidly to short notice orders. A solid equity base, a healthy understanding and insight regarding what is possible and essential, are prerequisites for optimal warehousing-

delivery- and logistical attitude of a company that wants to maintain a flexible response to the prevailing market situation. This puts us in the position of being able, when necessary, to act "ad hoc" in your best interest.



Bespoken work. Innovative product development.

Your KKC logistic systems and transport packaging will be matched or optimised to your products.

Regardless of whether a particular inner lining or a shock-resistant inner protection is required. Regardless of whether splash guard and dust protection or water tightness are required. We do not avoid checking regarding complex demands, e.g. of the

aviation industry, the army or hygiene industry. You can expect the right solution from us for all of your needs, regardless of the volume of the production series. Even complex electronic assembly with required (TÜV = Technical Inspection Certificate) safety seals presents no problem for us.



Tailored to suit a market need. Small and large volume order for production series.



KKC's production has been laid out for individuality and flexibility. Even the most extreme and unusual productions are possible. In order to meet these demands we have designed and perfected our production equipment.

Accordingly to our definition of quality we are working in lean production in the areas of sheet metal forming as well as injection moulding.

For the installation process we have designed the assembly areas so ergonomically and flexible that they are suitable for producing multiple dimensions.

This enables us to represent a good price performance ratio.



Creative. Simply challenge us.

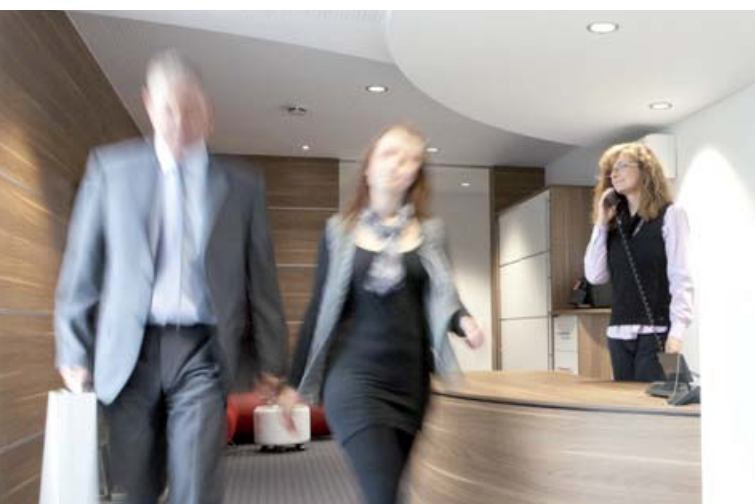

Today everyone is talking about motivated employees, customer-orientation, extreme flexibility, willingness to perform and so on, and so on ...

But please be sure:

We're already doing our utmost not only to win but also to keep you as a satisfied customer. In this "case" you can be absolutely certain.













CONTENT

References

3

Product lines

EXTREME	Aluminium Transport Boxes Light and safe	 	10	9
CARGO	Transport Containers made of high-tensile polyethylene Impact resistant and unbreakable	 	100	15
WATERPROOF-S	Plastic Cases Unbreakable and waterproof			25
PROFESSIONAL	Aluminium Frame Cases Light and safe	 	10	29
PRO WORKS	Aluminium Tool Cases The clever alternative	 	10	41
PRO WORKS FLIGHT	Aluminium Tool Cases Airworthy design	 	10	48

Features, Technique and Accessories

Technique	Mounting forms, explanation of all pictograms	51
Mobility	Rollers and retractable handles	52
Surfaces / Colours	Choice of materials for all product lines	54
Interior design	Foam inserts, deep-recessed inserts, dividing wall systems	56
		59

Explanation



Product line with available standard sizes



25

On order of 25 or more individual cases, the choice of width, depth and height is arbitrary

EXTREME

Sturdy Aluminium Transport Boxes





EXTREME - Alubox ALPHA.
The top model.

Professional quality of the **extreme** - alubox product line. For high demands regarding protection and transport, indispensable for storage of valuable and sensitive goods.

- Most stability thanks to 1.2 mm thick aluminium plate with pressed profile rills
- Top handling thanks to solid aluminium casting stacking corners
- Compatible with nearly all identically constructed products of different producer
- Permanent folding function using indestructible, continuous high quality steel hinge band
- Deep-seated rubber gasket as perfect protection against invasion of dust, humidity and splash water
- Additional strengthening using aluminium profiles which are welded on bottom and lid
- Sturdy, long lasting clip locks
- Further protection of the locks using sealing, padlock and clip against bursting of
- Solid full rivets on all riveted spots
- 50 kg weight-bearing capacity on the ergonomically formed and sturdy handles

Interior design is individually adaptable (see p. 59 and following pages).



Lock



Clasp handle



Aluminium stacking corner



Rubber gasket



Piano hinge

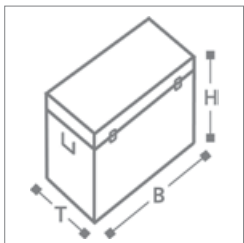

Type	W/D/H (mm) Outside dimensions	W/D/H (mm) Inside dimensions	Article No.
Alpha 27	400 x 300 x 340	350 x 250 x 310	505100.00
Alpha 44	600 x 400 x 250	550 x 350 x 230	505101.00
Alpha 62	600 x 400 x 340	550 x 350 x 320	505102.00
Alpha 73	600 x 400 x 410	550 x 350 x 380	505103.00
Alpha 67	600 x 600 x 260	550 x 550 x 220	505104.00
Alpha 115	600 x 600 x 420	550 x 550 x 380	505105.00
Alpha 175	600 x 600 x 620	550 x 550 x 580	505106.00
Alpha 84	800 x 400 x 340	750 x 350 x 320	505107.00
Alpha 157	800 x 600 x 410	750 x 550 x 380	505108.00
Alpha 239	800 x 600 x 610	750 x 550 x 580	505109.00
Alpha 423	1200 x 800 x 510	1150 x 750 x 490	505110.00

EXTREME - Alubox BRAVO. Low-priced and solid.

The composition of cost awareness and professionalism in the **extreme** - alubox product line. Professional features for most of the demands regarding protection and mobility as well as appropriate storage of valuable and sensitive goods.

- Most stability thanks to 1.0 mm thick aluminium plate with pressed profile and corner rills
 - Professional stackability thanks to solid aluminium casting stacking corners
 - **extreme** - boxes BRAVO and ALPHA are stackable
 - Compatible with nearly all identically constructed products of different producer
 - Two steel hinges and two positioning straps hold the opened lid
 - Deep-seated rubber gasket as perfect protection against invasion of dust, humidity and splash water
 - Additional strengthening using aluminium profiles which are welded on bottom and lid
 - Sturdy, long lasting clip locks
- Further protection of the locks using sealing, padlock and clip against bursting of



- 50 kg weight-bearing capacity on the ergonomically formed and sturdy handle
- Mounting of the aluminium casting stacking corners with full rivets, all other rivet connections are mounted with pop rivets

Interior design is individually adaptable (see p. 59 and following pages).



Lock



Clasp handle



Two solid hinges



Rubber gasket



Positioning strap / lid holder

Type	W/D/H (mm) Outside dimensions	W/D/H (mm) Inside dimensions	Article No.
Bravo 27	400 x 300 x 340	350 x 250 x 310	505200.00
Bravo 42	600 x 400 x 250	550 x 350 x 210	505201.00
Bravo 60	600 x 400 x 340	550 x 350 x 310	505203.00
Bravo 73	600 x 400 x 410	550 x 350 x 380	505204.00
Bravo 81	800 x 400 x 340	750 x 350 x 300	505205.00
Bravo 157	800 x 600 x 410	750 x 550 x 380	505206.00
Bravo 240	800 x 600 x 610	750 x 550 x 580	505207.00

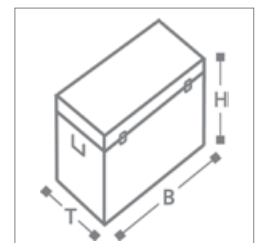



EXTREME - Alubox CHARLY.
Without frills, practical, at good value.

The **extreme** - alubox CHARLY combines high efficiency and low costs.

- Practical stability thanks to 0.8 mm thick aluminium plate with pressed profile rills
- Stackability thanks to profile lid and stacking rim
- Two steel hinges and two positioning straps hold the opened lid
- Deep-seated rubber gasket as perfect protection against invasion of dust, humidity and splash water
- Additional strengthening using aluminium profiles which are welded on bottom and lid

Interior design is individually adaptable (see p. 59 and following pages).



Two solid hinges



Clasp handle



Positioning strap / lid holder



Stacking rim



Welded stacking profiles

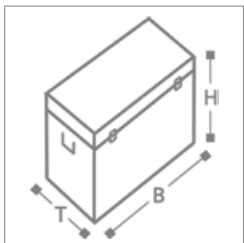

Type		W/D/H (mm) Outside dimensions	W/D/H (mm) Inside dimensions	Article No.
Charly 29		380 x 280 x 350	360 x 260 x 320	505301.00
Charly 47		570 x 370 x 270	550 x 350 x 240	505302.00
Charly 70		580 x 380 x 380	560 x 360 x 350	505303.00
Charly 90		770 x 370 x 380	750 x 350 x 350	505304.00
Charly 140		890 x 480 x 380	870 x 460 x 350	505305.00

EXTREME - the Alubox SYSTEM. Comprehensive, thought out and flexible.

Aluminium is the basic material in future for comprehensive use.

- Light and solid
- Odourless and hygienic
- Corrosion-resistant and weather-resistant
- Magnetic neutral
- Immune to temperature variations
- Completely recycable

KKC offers the **extreme** - alubox SYSTEM in great variety for the countless uses. Hence the right size with the right interior design is available for every area.

Even for the transportation area the **extreme** - alubox SYSTEM offers appropriate solutions. Diverse trolleys and transport trolleys allow simple conversion.

For further stacking euro-pallets made of aluminium offer compatibility to other stacking systems.





Perforated U-Box

Perforated U-boxes, e.g. for clammy contents which need to be ventilated well (for example wet clothes after a fire brigade action, clammy laundry but also fresh meat or something like that) or warm contents during cooling (for example thermoplastic production, fresh bakery or something like that).

EXTREME - the Alu U-Box. For logistic and stock circulation.

extreme - the open U-box as perfect collecting box for daily routines in logistic and warehouse management. These open transport boxes are designed for industrial use corresponding to the measurements of euro-pallets.

Also excellent for transport or storage of groceries in bakeries, gastronomy or pharmacy.

- Light and solid
- High stability thanks to 1.0 mm thick aluminium plate
- Quick comparison of label and product
- Stackability thanks to stacking rim
- Compatible with nearly all identically constructed products of different producer
- Sturdy, ergonomically formed spring clasp handles with positioning function up to 50 kg weight-bearing capacity
- 4 handles on the perforated U-box for using in drawer functionality



Type	W/D/H (mm) Inside dimensions	Article No.	perforated, 4 handles	closed, 2 handles
U-Box	550 x 350 x 300		505351.00	505351.01
U-Box	750 x 550 x 300		505352.00	505351.02



EXTREME - Trolley. For easy handling.

Intelligent solutions for easy transport of the aluminium boxes.

Absolute solid installation of the trolley, mounted on bottom of box. With a simple clip mechanism the solid trolley is fixed. The retractable handle and the large rollers with rubber gripping surface enable easy transport even of heavy loads.

Trolley functionality on request.

CARGOBOX

High-tensile and light reusable transport boxes





CARGO - Highly stressable reusable transport boxes and storage containers.

The CARGO container system protects your high-quality, sensitive products perfectly during transport. Almost indestructible and compared to its volume feathery; the available standard range offers a solution for nearly every use of application. As reusable packaging, storage packaging or transport system and flight case.

Even when using this system for international air cargo and maritime freight, the advantages are realized.

- 400 different standard sizes
- Extreme stability, impact-, scratching- and breaking-resistance
- Light - low own weight = low transport costs
- Stackable
- Long-lasting, permanent reusability
- Splash guard up to IP 65 (optional)
- Resistant to chemical impacts
- Suitable for air freight according to ATA 300 code
- 8 standard colours available

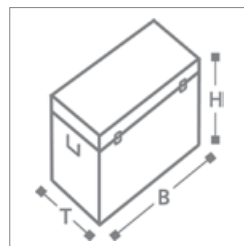

W/D/H (mm) Inside dimensions	W/D/H (mm) Outside dimensions	Article No.
155 x 155 x 110 + 110	180 x 200 x 250	C3-1515-1010
155 x 155 x 110 + 55	180 x 200 x 195	C3-1515-1055
285 x 250 x 130 + 80	305 x 285 x 240	C3-2825-3080
280 x 250 x 165 + 160	305 x 285 x 350	C3-2825-6560
300 x 195 x 80 + 90	325 x 240 x 205	C3-3019-8090
340 x 320 x 220 + 105	400 x 380 x 365	C3-3432-2005
340 x 320 x 320 + 105	400 x 380 x 465	C3-3432-2006
340 x 320 x 320 + 320	400 x 380 x 690	C3-3432-2020
340 x 320 x 320 + 240	400 x 380 x 600	C3-3432-2040
340 x 320 x 230 + 240	400 x 380 x 510	C3-3432-3040
350 x 245 x 125 + 135	380 x 290 x 290	C3-3524-2535
350 x 245 x 125 + 75	380 x 290 x 230	C3-3524-2575
355 x 245 x 130 + 75	385 x 275 x 240	C3-3524-3075
350 x 245 x 65 + 75	380 x 290 x 170	C3-3524-6575
355 x 290 x 100 + 75	405 x 335 x 205	C3-3529-0075
355 x 290 x 140 + 75	405 x 335 x 245	C3-3529-4075
355 x 290 x 190 + 75	405 x 335 x 295	C3-3529-9075
370 x 330 x 105 + 115	400 x 380 x 240	C3-3733-0515
380 x 320 x 240 + 95	420 x 370 x 355	C3-3832-4095
410 x 220 x 240 + 125	440 x 250 x 390	C3-4122-4025
410 x 330 x 85 + 70	460 x 385 x 170	C3-4133-8570
420 x 210 x 245 + 85	465 x 250 x 360	C3-4221-4585
430 x 190 x 185 + 55	480 x 240 x 260	C3-4319-8555
430 x 190 x 185 + 185	480 x 240 x 390	C3-4319-8585

W/D/H (mm) Inside dimensions	W/D/H (mm) Outside dimensions	Article No.
430 x 270 x 120 + 55	480 x 320 x 195	C3-4327-2055
430 x 270 x 185 + 120	480 x 320 x 325	C3-4327-8520
430 x 270 x 185 + 55	480 x 320 x 260	C3-4327-8555
430 x 270 x 185 + 185	480 x 320 x 390	C3-4327-8585
430 x 350 x 120 + 55	480 x 400 x 195	C3-4335-2055
430 x 350 x 185 + 120	480 x 400 x 325	C3-4335-8520
430 x 350 x 185 + 55	480 x 400 x 260	C3-4335-8555
430 x 350 x 185 + 185	480 x 400 x 390	C3-4335-8585
430 x 430 x 120 + 55	480 x 480 x 195	C3-4343-2055
430 x 430 x 185 + 120	480 x 480 x 325	C3-4343-8520
430 x 430 x 185 + 55	480 x 480 x 260	C3-4343-8555
430 x 430 x 185 + 185	480 x 480 x 390	C3-4343-8585
445 x 300 x 300 + 150	490 x 350 x 480	C3-4430-0050
445 x 300 x 180 + 150	490 x 350 x 360	C3-4430-8050
445 x 355 x 130 + 100	465 x 405 x 315	C3-4435-3000
445 x 355 x 130 + 55	465 x 405 x 270	C3-4435-3055
445 x 355 x 80 + 100	465 x 405 x 210	C3-4435-8000
445 x 355 x 80 + 55	465 x 405 x 165	C3-4435-8055
445 x 355 x 185 + 100	465 x 405 x 315	C3-4435-8500
445 x 355 x 185 + 55	465 x 405 x 270	C3-4435-8555
445 x 355 x 185 + 190	465 x 405 x 405	C3-4435-8590
440 x 440 x 330 + 145	495 x 495 x 495	C3-4444-3045
440 x 440 x 330 + 90	495 x 495 x 440	C3-4444-3090
440 x 440 x 280 + 145	495 x 495 x 445	C3-4444-8045
440 x 440 x 280 + 90	495 x 495 x 390	C3-4444-8090
460 x 215 x 105 + 105	490 x 240 x 240	C3-4621-0505
475 x 390 x 130 + 100	495 x 440 x 260	C3-4739-3000
475 x 390 x 130 + 55	495 x 440 x 215	C3-4739-3055
475 x 390 x 185 + 100	495 x 440 x 315	C3-4739-8500
475 x 390 x 185 + 55	495 x 440 x 270	C3-4739-8555
475 x 390 x 185 + 190	495 x 440 x 405	C3-4739-8590
480 x 365 x 110 + 115	530 x 410 x 245	C3-4836-1015
480 x 365 x 210 + 115	530 x 410 x 345	C3-4836-1016
480 x 365 x 210 + 215	530 x 410 x 445	C3-4836-1017
480 x 365 x 210 + 170	530 x 410 x 400	C3-4836-1070
480 x 365 x 255 + 115	530 x 410 x 390	C3-4836-5515
480 x 365 x 255 + 215	530 x 410 x 490	C3-4836-5516
480 x 365 x 255 + 260	530 x 410 x 535	C3-4836-5560
480 x 365 x 255 + 170	530 x 410 x 445	C3-4836-5570
480 x 365 x 165 + 115	530 x 410 x 300	C3-4836-6515
480 x 365 x 165 + 170	530 x 410 x 355	C3-4836-6570
495 x 370 x 110 + 115	515 x 425 x 265	C3-4937-1015
495 x 370 x 110 + 55	515 x 425 x 205	C3-4937-1055
495 x 370 x 125 + 130	515 x 415 x 280	C3-4937-2530
495 x 370 x 130 + 55	515 x 415 x 210	C3-4937-3055
495 x 370 x 140 + 115	515 x 425 x 295	C3-4937-4015
495 x 370 x 140 + 145	515 x 425 x 325	C3-4937-4045
495 x 370 x 140 + 55	515 x 425 x 235	C3-4937-4055
495 x 370 x 75 + 55	515 x 425 x 170	C3-4937-7555
495 x 370 x 90 + 55	515 x 415 x 170	C3-4937-9055
500 x 370 x 135 + 140	535 x 415 x 285	C3-5037-3540

W/D/H (mm) Inside dimensions	W/D/H (mm) Outside dimensions	Article No.
500 x 500 x 240 + 250	550 x 550 x 530	C3-5050-4050
510 x 200 x 120 + 55	560 x 240 x 195	C3-5120-2055
510 x 200 x 185 + 120	560 x 240 x 325	C3-5120-8520
510 x 200 x 185 + 55	560 x 240 x 260	C3-5120-8555
510 x 200 x 185 + 185	560 x 240 x 390	C3-5120-8585
510 x 270 x 120 + 55	560 x 320 x 195	C3-5127-2055
510 x 270 x 185 + 120	560 x 320 x 325	C3-5127-8520
510 x 270 x 185 + 55	560 x 320 x 260	C3-5127-8555
510 x 270 x 185 + 185	560 x 320 x 390	C3-5127-8585
515 x 315 x 205 + 60	565 x 365 x 290	C3-5131-0560
515 x 315 x 280 + 80	565 x 365 x 380	C3-5131-8080
510 x 350 x 120 + 55	560 x 400 x 195	C3-5135-2055
510 x 350 x 185 + 120	560 x 400 x 325	C3-5135-8520
510 x 350 x 185 + 55	560 x 400 x 260	C3-5135-8555
510 x 350 x 185 + 185	560 x 400 x 390	C3-5135-8585
510 x 430 x 120 + 55	560 x 480 x 195	C3-5143-2055
510 x 430 x 185 + 120	560 x 480 x 325	C3-5143-8520
510 x 430 x 185 + 55	560 x 480 x 260	C3-5143-8555
510 x 430 x 185 + 185	560 x 480 x 390	C3-5143-8585
510 x 510 x 120 + 55	560 x 560 x 195	C3-5151-2055
510 x 510 x 185 + 120	560 x 560 x 325	C3-5151-8520
510 x 510 x 185 + 55	560 x 560 x 260	C3-5151-8555
510 x 510 x 185 + 185	560 x 560 x 390	C3-5151-8585
530 x 550 x 140 + 105	620 x 605 x 275	C3-5355-4005
530 x 550 x 140 + 150	620 x 605 x 320	C3-5355-4050
530 x 550 x 255 + 105	620 x 605 x 390	C3-5355-5505
530 x 550 x 255 + 205	620 x 605 x 490	C3-5355-5506
530 x 550 x 255 + 150	620 x 605 x 435	C3-5355-5550
530 x 550 x 255 + 265	620 x 605 x 550	C3-5355-5565
530 x 550 x 95 + 105	620 x 605 x 230	C3-5355-9505
530 x 550 x 195 + 105	620 x 605 x 330	C3-5355-9506
530 x 550 x 195 + 205	620 x 605 x 430	C3-5355-9507
530 x 550 x 195 + 150	620 x 605 x 375	C3-5355-9550
550 x 350 x 285 + 105	605 x 405 x 410	C3-5535-8505
560 x 260 x 145 + 150	590 x 295 x 335	C3-5626-4550
565 x 265 x 285 + 140	600 x 310 x 460	C3-5626-8540
560 x 365 x 140 + 70	615 x 420 x 235	C3-5636-4070
560 x 365 x 55 + 45	615 x 420 x 125	C3-5636-5545
565 x 360 x 390 + 205	615 x 410 x 625	C3-5636-9005
565 x 360 x 195 + 205	615 x 410 x 440	C3-5636-9505
560 x 365 x 95 + 45	615 x 420 x 165	C3-5636-9545
565 x 450 x 115 + 125	620 x 500 x 250	C3-5645-1525
565 x 450 x 145 + 155	620 x 500 x 310	C3-5645-4555
580 x 450 x 100 + 110	635 x 510 x 230	C3-5845-0010
580 x 450 x 200 + 110	635 x 510 x 330	C3-5845-0011
580 x 450 x 200 + 210	635 x 510 x 420	C3-5845-0012
580 x 450 x 300 + 110	635 x 510 x 425	C3-5845-0013
580 x 450 x 300 + 210	635 x 510 x 520	C3-5845-0014
580 x 450 x 300 + 310	635 x 510 x 620	C3-5845-0015
585 x 510 x 115 + 125	635 x 560 x 270	C3-5851-1525
590 x 190 x 120 + 55	640 x 240 x 195	C3-5919-2055

CARGO



100

W/D/H (mm) Inside dimensions	W/D/H (mm) Outside dimensions	Article No.	W/D/H (mm) Inside dimensions	W/D/H (mm) Outside dimensions	Article No.
590 x 190 x 185 + 120	640 x 240 x 325	C3-5919-8520	670 x 270 x 120 + 55	720 x 320 x 195	C3-6727-2055
590 x 190 x 185 + 55	640 x 240 x 260	C3-5919-8555	670 x 270 x 185 + 120	720 x 320 x 325	C3-6727-8520
590 x 190 x 185 + 185	640 x 240 x 390	C3-5919-8585	670 x 270 x 185 + 55	720 x 320 x 260	C3-6727-8555
590 x 270 x 120 + 55	640 x 320 x 195	C3-5927-2055	670 x 270 x 185 + 185	720 x 320 x 390	C3-6727-8585
590 x 270 x 185 + 120	640 x 320 x 325	C3-5927-8520	670 x 350 x 120 + 55	720 x 400 x 195	C3-6735-2055
590 x 270 x 185 + 55	640 x 320 x 260	C3-5927-8555	670 x 350 x 185 + 120	720 x 400 x 325	C3-6735-8520
590 x 270 x 185 + 185	640 x 320 x 390	C3-5927-8585	670 x 350 x 185 + 55	720 x 400 x 260	C3-6735-8555
590 x 350 x 120 + 55	640 x 400 x 195	C3-5935-2055	670 x 350 x 185 + 185	720 x 400 x 390	C3-6735-8585
590 x 350 x 185 + 120	640 x 400 x 325	C3-5935-8520	670 x 430 x 120 + 55	720 x 480 x 195	C3-6743-2055
590 x 350 x 185 + 55	640 x 400 x 260	C3-5935-8555	670 x 430 x 185 + 120	720 x 480 x 325	C3-6743-8520
590 x 350 x 185 + 185	640 x 400 x 390	C3-5935-8585	670 x 430 x 185 + 55	720 x 480 x 260	C3-6743-8555
590 x 350 x 190 + 125	615 x 405 x 345	C3-5935-9025	670 x 430 x 185 + 185	720 x 480 x 390	C3-6743-8585
590 x 350 x 190 + 65	615 x 405 x 285	C3-5935-9065	670 x 510 x 120 + 55	720 x 560 x 195	C3-6751-2055
590 x 350 x 190 + 195	615 x 405 x 415	C3-5935-9095	670 x 510 x 185 + 120	720 x 560 x 325	C3-6751-8520
590 x 430 x 120 + 125	650 x 490 x 275	C3-5943-2025	670 x 510 x 185 + 55	720 x 560 x 260	C3-6751-8555
590 x 430 x 120 + 55	650 x 490 x 205	C3-5943-2056	670 x 510 x 185 + 185	720 x 560 x 390	C3-6751-8585
590 x 430 x 120 + 55	640 x 480 x 195	C3-5943-2057	670 x 590 x 120 + 55	720 x 640 x 195	C3-6759-2055
590 x 430 x 185 + 120	640 x 480 x 325	C3-5943-8520	670 x 590 x 185 + 120	720 x 640 x 325	C3-6759-8520
590 x 430 x 185 + 55	640 x 480 x 260	C3-5943-8555	670 x 590 x 185 + 55	720 x 640 x 260	C3-6759-8555
590 x 430 x 185 + 185	640 x 480 x 390	C3-5943-8585	670 x 590 x 185 + 185	720 x 640 x 390	C3-6759-8585
590 x 510 x 120 + 55	640 x 560 x 195	C3-5951-2055	670 x 670 x 120 + 55	720 x 720 x 195	C3-6767-2055
590 x 510 x 185 + 120	640 x 560 x 325	C3-5951-8520	670 x 670 x 185 + 120	720 x 720 x 325	C3-6767-8520
590 x 510 x 185 + 55	640 x 560 x 260	C3-5951-8555	670 x 670 x 185 + 55	720 x 720 x 260	C3-6767-8555
590 x 510 x 185 + 185	640 x 560 x 390	C3-5951-8585	670 x 670 x 185 + 185	720 x 720 x 390	C3-6767-8585
590 x 590 x 120 + 55	640 x 640 x 195	C3-5959-2055	680 x 325 x 280 + 80	730 x 375 x 380	C3-6832-8080
595 x 595 x 250 + 250	650 x 650 x 530	C3-5959-5050	680 x 345 x 235 + 45	725 x 390 x 305	C3-6834-3545
590 x 590 x 185 + 120	640 x 640 x 325	C3-5959-8520	680 x 345 x 175 + 45	725 x 390 x 245	C3-6834-7545
590 x 590 x 185 + 55	640 x 640 x 260	C3-5959-8555	680 x 345 x 295 + 45	725 x 390 x 365	C3-6834-9545
590 x 590 x 185 + 185	640 x 640 x 390	C3-5959-8585	680 x 515 x 280 + 80	730 x 565 x 380	C3-6851-8080
610 x 480 x 150 + 165	660 x 525 x 330	C3-6148-5065	680 x 620 x 100 + 100	730 x 670 x 230	C3-6862-0000
610 x 480 x 155 + 95	660 x 525 x 265	C3-6148-5595	695 x 150 x 105 + 110	720 x 170 x 230	C3-6915-0510
620 x 350 x 105 + 115	680 x 400 x 240	C3-6235-0515	705 x 280 x 220 + 140	750 x 330 x 390	C3-7028-2040
620 x 350 x 155 + 115	680 x 400 x 290	C3-6235-5515	705 x 280 x 220 + 50	750 x 330 x 300	C3-7028-2050
620 x 350 x 255 + 115	680 x 400 x 390	C3-6235-5516	705 x 280 x 150 + 50	750 x 330 x 230	C3-7028-5050
620 x 350 x 355 + 115	680 x 400 x 490	C3-6235-5517	705 x 280 x 280 + 140	750 x 330 x 450	C3-7028-8040
620 x 350 x 155 + 165	680 x 400 x 340	C3-6235-5565	705 x 280 x 280 + 50	750 x 330 x 360	C3-7028-8050
620 x 350 x 255 + 165	680 x 400 x 440	C3-6235-5566	710 x 280 x 135 + 140	760 x 330 x 315	C3-7128-3540
620 x 350 x 255 + 265	680 x 400 x 540	C3-6235-5567	745 x 340 x 200 + 200	800 x 390 x 430	C3-7434-0000
620 x 350 x 355 + 165	680 x 400 x 540	C3-6235-5568	740 x 340 x 110 + 110	790 x 390 x 260	C3-7434-1010
620 x 350 x 355 + 265	680 x 400 x 640	C3-6235-5569	750 x 210 x 75 + 75	770 x 250 x 175	C3-7521-7575
620 x 350 x 355 + 365	680 x 400 x 740	C3-6235-5570	750 x 330 x 220 + 140	800 x 375 x 390	C3-7533-2040
620 x 350 x 155 + 75	680 x 400 x 260	C3-6235-5575	750 x 330 x 220 + 50	800 x 375 x 300	C3-7533-2050
620 x 350 x 255 + 75	680 x 400 x 360	C3-6235-5576	750 x 330 x 150 + 50	800 x 375 x 230	C3-7533-5050
620 x 350 x 355 + 75	680 x 400 x 460	C3-6235-5577	750 x 330 x 280 + 140	800 x 375 x 450	C3-7533-8040
625 x 520 x 100 + 100	670 x 565 x 225	C3-6252-0000	750 x 330 x 280 + 50	800 x 375 x 360	C3-7533-8050
640 x 405 x 125 + 130	665 x 450 x 280	C3-6440-2530	750 x 350 x 120 + 55	800 x 400 x 195	C3-7535-2055
640 x 405 x 130 + 55	665 x 450 x 210	C3-6440-3055	750 x 350 x 185 + 120	800 x 400 x 325	C3-7535-8520
640 x 405 x 90 + 55	665 x 450 x 170	C3-6440-9055	750 x 350 x 185 + 55	800 x 400 x 260	C3-7535-8555
650 x 555 x 240 + 100	700 x 600 x 380	C3-6555-4000	750 x 350 x 185 + 185	800 x 400 x 390	C3-7535-8585
660 x 570 x 385 + 395	700 x 610 x 805	C3-6657-8595	750 x 430 x 120 + 55	800 x 480 x 195	C3-7543-2055
665 x 665 x 340 + 170	710 x 710 x 540	C3-6666-4070	750 x 430 x 185 + 120	800 x 480 x 325	C3-7543-8520

CARGO



100

W/D/H (mm) Inside dimensions	W/D/H (mm) Outside dimensions	Article No.
750 x 430 x 185 + 55	800 x 480 x 260	C3-7543-8555
750 x 430 x 185 + 185	800 x 480 x 390	C3-7543-8585
750 x 510 x 120 + 55	800 x 560 x 195	C3-7551-2055
750 x 510 x 185 + 120	800 x 560 x 325	C3-7551-8520
750 x 510 x 185 + 55	800 x 560 x 260	C3-7551-8555
750 x 510 x 185 + 185	800 x 560 x 390	C3-7551-8585
755 x 555 x 325 + 330	805 x 605 x 505	C3-7555-2530
755 x 555 x 325 + 235	805 x 605 x 505	C3-7555-2535
755 x 555 x 325 + 150	805 x 605 x 505	C3-7555-2550
755 x 555 x 325 + 55	805 x 605 x 410	C3-7555-2555
755 x 555 x 230 + 235	805 x 605 x 410	C3-7555-3035
755 x 555 x 230 + 150	805 x 605 x 410	C3-7555-3050
755 x 555 x 230 + 55	805 x 605 x 410	C3-7555-3055
755 x 555 x 140 + 150	805 x 605 x 320	C3-7555-4050
755 x 555 x 140 + 55	805 x 605 x 225	C3-7555-4055
755 x 555 x 50 + 55	805 x 605 x 135	C3-7555-5055
755 x 555 x 385 + 330	805 x 605 x 565	C3-7555-8530
755 x 555 x 385 + 235	805 x 605 x 565	C3-7555-8535
755 x 555 x 385 + 150	805 x 605 x 565	C3-7555-8550
755 x 555 x 385 + 55	805 x 605 x 470	C3-7555-8555
755 x 555 x 385 + 390	805 x 605 x 565	C3-7555-8590
750 x 590 x 120 + 55	800 x 640 x 195	C3-7559-2055
750 x 590 x 185 + 120	800 x 640 x 325	C3-7559-8520
750 x 590 x 185 + 55	800 x 640 x 260	C3-7559-8555
750 x 590 x 185 + 185	800 x 640 x 390	C3-7559-8585
750 x 655 x 295 + 305	820 x 720 x 630	C3-7565-9505
750 x 670 x 120 + 55	800 x 720 x 195	C3-7567-2055
750 x 670 x 185 + 120	800 x 720 x 325	C3-7567-8520
750 x 670 x 185 + 55	800 x 720 x 260	C3-7567-8555
750 x 670 x 185 + 185	800 x 720 x 390	C3-7567-8585
750 x 750 x 120 + 55	800 x 800 x 195	C3-7575-2055
750 x 750 x 185 + 120	800 x 800 x 325	C3-7575-8520
750 x 750 x 185 + 55	800 x 800 x 260	C3-7575-8555
750 x 750 x 185 + 185	800 x 800 x 390	C3-7575-8585
764 x 356 x 320 + 125	820 x 405 x 495	C3-7635-2025
764 x 356 x 320 + 80	820 x 405 x 450	C3-7635-2080
764 x 356 x 280 + 125	820 x 405 x 455	C3-7635-8025
764 x 356 x 280 + 80	820 x 405 x 410	C3-7635-8080
785 x 525 x 100 + 105	830 x 570 x 235	C3-7852-0005
785 x 525 x 330 + 105	830 x 570 x 470	C3-7852-3005
785 x 525 x 330 + 195	830 x 570 x 560	C3-7852-3095
785 x 525 x 335 + 260	830 x 570 x 630	C3-7852-3560
785 x 525 x 255 + 105	830 x 570 x 395	C3-7852-5505
785 x 525 x 255 + 195	830 x 570 x 480	C3-7852-5595
785 x 525 x 190 + 105	830 x 570 x 325	C3-7852-9005
785 x 525 x 190 + 195	830 x 570 x 415	C3-7852-9095
780 x 760 x 80 + 90	850 x 850 x 210	C3-7876-8090
780 x 760 x 180 + 90	850 x 850 x 315	C3-7876-8091
780 x 760 x 180 + 190	850 x 850 x 410	C3-7876-8092
780 x 760 x 385 + 90	850 x 850 x 515	C3-7876-8590
780 x 760 x 385 + 190	850 x 850 x 615	C3-7876-8591

W/D/H (mm) Inside dimensions	W/D/H (mm) Outside dimensions	Article No.
780 x 760 x 385 + 395	850 x 850 x 820	C3-7876-8595
800 x 445 x 400 + 95	850 x 500 x 530	C3-8044-0095
800 x 800 x 240 + 110	850 x 850 x 415	C3-8080-4010
800 x 800 x 240 + 245	850 x 850 x 550	C3-8080-4045
800 x 800 x 240 + 165	850 x 850 x 470	C3-8080-4065
800 x 800 x 170 + 110	850 x 850 x 345	C3-8080-7010
800 x 800 x 170 + 165	850 x 850 x 400	C3-8080-7065
845 x 575 x 205 + 215	890 x 620 x 450	C3-8457-0515
845 x 575 x 305 + 215	890 x 620 x 550	C3-8457-0516
845 x 575 x 305 + 315	890 x 620 x 650	C3-8457-0517
845 x 575 x 205 + 165	890 x 620 x 400	C3-8457-0565
845 x 575 x 305 + 165	890 x 620 x 500	C3-8457-0566
845 x 575 x 305 + 265	890 x 620 x 600	C3-8457-0567
845 x 575 x 205 + 80	890 x 620 x 315	C3-8457-0580
845 x 575 x 305 + 80	890 x 620 x 415	C3-8457-0581
845 x 575 x 155 + 165	890 x 620 x 350	C3-8457-5565
845 x 575 x 255 + 265	890 x 620 x 550	C3-8457-5566
845 x 575 x 155 + 80	890 x 620 x 265	C3-8457-5580
845 x 575 x 260 + 215	890 x 620 x 505	C3-8457-6015
845 x 575 x 260 + 165	890 x 620 x 455	C3-8457-6065
845 x 575 x 260 + 80	890 x 620 x 370	C3-8457-6080
840 x 640 x 290 + 290	890 x 690 x 620	C3-8464-9090
875 x 350 x 260 + 125	1455 x 405 x 415	C3-8735-6025
875 x 350 x 260 + 65	1455 x 405 x 355	C3-8735-6065
875 x 350 x 260 + 265	1455 x 405 x 555	C3-8735-6066
875 x 350 x 260 + 195	1455 x 405 x 485	C3-8735-6095
875 x 350 x 190 + 125	1455 x 405 x 345	C3-8735-9025
875 x 350 x 190 + 65	1455 x 405 x 285	C3-8735-9065
875 x 350 x 190 + 195	1455 x 405 x 415	C3-8735-9095
880 x 280 x 105 + 110	940 x 330 x 235	C3-8828-0510
880 x 280 x 220 + 110	940 x 330 x 350	C3-8828-2010
880 x 280 x 220 + 225	940 x 330 x 465	C3-8828-2025
880 x 450 x 105 + 115	945 x 510 x 250	C3-8845-0515
880 x 450 x 205 + 115	945 x 510 x 350	C3-8845-0516
880 x 450 x 205 + 215	945 x 510 x 450	C3-8845-0517
880 x 450 x 305 + 115	945 x 510 x 450	C3-8845-0518
880 x 450 x 305 + 215	945 x 510 x 550	C3-8845-0519
880 x 450 x 305 + 315	945 x 510 x 650	C3-8845-0520
895 x 510 x 90 + 95	955 x 565 x 215	C3-8951-9095
895 x 510 x 190 + 95	955 x 565 x 315	C3-8951-9096
895 x 510 x 190 + 195	955 x 565 x 415	C3-8951-9097
905 x 905 x 100 + 110	970 x 970 x 260	C3-9090-0010
905 x 905 x 190 + 110	970 x 970 x 350	C3-9090-9010
905 x 905 x 190 + 195	970 x 970 x 435	C3-9090-9095
915 x 725 x 290 + 300	990 x 770 x 620	C3-9172-9000
915 x 725 x 190 + 150	990 x 770 x 370	C3-9172-9050
940 x 540 x 100 + 110	990 x 580 x 250	C3-9454-0010
940 x 540 x 280 + 110	990 x 580 x 430	C3-9454-8010
940 x 540 x 280 + 290	990 x 580 x 610	C3-9454-8090
958 x 680 x 130 + 140	1020 x 740 x 310	C3-9568-3040
958 x 680 x 130 + 90	1020 x 740 x 260	C3-9568-3090

W/D/H (mm) Inside dimensions	W/D/H (mm) Outside dimensions	Article No.
958 x 680 x 80 + 90	1020 x 740 x 210	C3-9568-8090
958 x 680 x 390 + 400	1020 x 740 x 830	C3-9568-9000
958 x 680 x 390 + 140	1020 x 740 x 570	C3-9568-9040
958 x 680 x 390 + 90	1020 x 740 x 520	C3-9568-9090
975 x 370 x 130 + 140	995 x 420 x 300	C3-9737-3040
975 x 370 x 130 + 55	995 x 420 x 215	C3-9737-3055
980 x 570 x 170 + 100	1035 x 625 x 310	C3-9857-7000
980 x 570 x 170 + 180	1035 x 625 x 390	C3-9857-7080
980 x 570 x 285 + 100	1035 x 625 x 425	C3-9857-8500
980 x 570 x 285 + 180	1035 x 625 x 505	C3-9857-8580
980 x 570 x 285 + 295	1035 x 625 x 620	C3-9857-8595
995 x 810 x 195 + 205	1065 x 880 x 440	C3-9981-9505
1020 x 145 x 95 + 105	1045 x 185 x 215	C4-1014-9505
1045 x 210 x 75 + 75	1070 x 250 x 175	C4-1021-7575
1045 x 260 x 105 + 110	1070 x 310 x 240	C4-1026-0510
1005 x 290 x 105 + 110	1056 x 313 x 245	C4-1029-0510
1005 x 290 x 225 + 110	1056 x 313 x 365	C4-1029-2510
1010 x 650 x 150 + 160	1060 x 700 x 350	C4-1065-5060
1090 x 865 x 50 + 60	1140 x 915 x 140	C4-1086-5060
1115 x 255 x 115 + 60	1135 x 305 x 235	C4-1125-1560
1115 x 255 x 60 + 60	1135 x 305 x 180	C4-1125-6060
1170 x 350 x 180 + 190	1225 x 410 x 395	C4-1135-8090
1195 x 405 x 250 + 160	1245 x 450 x 435	C4-1140-5060
1195 x 405 x 155 + 160	1245 x 450 x 340	C4-1140-5560
1170 x 495 x 130 + 135	1230 x 540 x 285	C4-1149-3035
1170 x 495 x 130 + 60	1230 x 540 x 210	C4-1149-3060
1150 x 750 x 180 + 90	1220 x 820 x 410	C4-1175-8090
1150 x 750 x 180 + 190	1220 x 820 x 410	C4-1175-8091
1150 x 750 x 280 + 90	1220 x 820 x 510	C4-1175-8092
1150 x 750 x 280 + 190	1220 x 820 x 510	C4-1175-8093
1150 x 750 x 280 + 290	1220 x 820 x 610	C4-1175-8094
1150 x 750 x 85 + 90	1220 x 820 x 410	C4-1175-8590
1150 x 750 x 385 + 90	1220 x 820 x 615	C4-1175-8591
1150 x 750 x 385 + 190	1220 x 820 x 615	C4-1175-8592
1150 x 750 x 385 + 290	1220 x 820 x 715	C4-1175-8593
1150 x 750 x 385 + 395	1220 x 820 x 820	C4-1175-8595
1220 x 1020 x 280 + 100	1290 x 1080 x 400	C4-1210-8000
1220 x 1020 x 280 + 285	1290 x 1080 x 585	C4-1210-8085
1220 x 1020 x 95 + 100	1290 x 1080 x 215	C4-1210-9500
1275 x 260 x 100 + 115	1300 x 310 x 240	C4-1226-0015
1275 x 260 x 100 + 70	1300 x 310 x 200	C4-1226-0070
1275 x 260 x 65 + 70	1300 x 310 x 160	C4-1226-6570
1240 x 830 x 210 + 105	1285 x 875 x 345	C4-1283-1005
1340 x 390 x 130 + 130	1395 x 435 x 290	C4-1339-3030
1340 x 390 x 130 + 60	1395 x 435 x 220	C4-1339-3060
1340 x 390 x 130 + 95	1395 x 435 x 255	C4-1339-3095
1340 x 390 x 355 + 130	1395 x 435 x 515	C4-1339-5530
1340 x 390 x 355 + 60	1395 x 435 x 445	C4-1339-5560
1340 x 390 x 355 + 360	1395 x 435 x 745	C4-1339-5561
1340 x 390 x 355 + 180	1395 x 435 x 565	C4-1339-5580
1340 x 390 x 355 + 95	1395 x 435 x 480	C4-1339-5595

W/D/H (mm) Inside dimensions	W/D/H (mm) Outside dimensions	Article No.
1340 x 390 x 180 + 130	1395 x 435 x 340	C4-1339-8030
1340 x 390 x 180 + 60	1395 x 435 x 270	C4-1339-8060
1340 x 390 x 180 + 180	1395 x 435 x 390	C4-1339-8080
1340 x 390 x 180 + 95	1395 x 435 x 305	C4-1339-8095
1340 x 390 x 90 + 60	1395 x 435 x 180	C4-1339-9060
1340 x 390 x 90 + 95	1395 x 435 x 215	C4-1339-9095
1335 x 645 x 200 + 210	1400 x 710 x 450	C4-1364-0010
1300 x 700 x 335 + 345	1360 x 755 x 715	C4-1370-3545
1300 x 700 x 335 + 190	1360 x 755 x 560	C4-1370-3590
1300 x 700 x 180 + 190	1360 x 755 x 405	C4-1370-8090
1430 x 1125 x 50 + 60	1480 x 1175 x 140	C4-1411-5060
1430 x 350 x 190 + 125	1455 x 405 x 345	C4-1435-9025
1430 x 350 x 190 + 65	1455 x 405 x 285	C4-1435-9065
1430 x 350 x 190 + 195	1455 x 405 x 415	C4-1435-9095
1400 x 495 x 130 + 135	1450 x 550 x 285	C4-1449-3035
1400 x 495 x 130 + 60	1450 x 550 x 210	C4-1449-3060
1420 x 570 x 320 + 140	1490 x 635 x 510	C4-1457-2040
1420 x 570 x 320 + 80	1490 x 635 x 450	C4-1457-2080
1495 x 580 x 200 + 200	1540 x 630 x 420	C4-1458-0000
1495 x 580 x 200 + 80	1540 x 630 x 300	C4-1458-0080
1495 x 580 x 80 + 80	1540 x 630 x 180	C4-1458-8080
1490 x 800 x 380 + 410	1560 x 870 x 810	C4-1480-8010
1490 x 800 x 390 + 100	1560 x 870 x 540	C4-1480-9000
1490 x 800 x 390 + 150	1560 x 870 x 590	C4-1480-9050
1690 x 210 x 75 + 75	1740 x 250 x 175	C4-1621-7575
1690 x 575 x 205 + 215	1760 x 650 x 470	C4-1657-0515



W/D/H (mm) Inside dimensions	W/D/H (mm) Outside dimensions	Article No.
1610 x 870 x 330 + 340	1680 x 950 x 690	C4-1687-3040
1785 x 360 x 160 + 55	1840 x 400 x 245	C4-1736-6055
1785 x 360 x 160 + 165	1840 x 400 x 355	C4-1736-6065
1825 x 165 x 130 + 135	1845 x 225 x 290	C4-1816-3035
1825 x 165 x 130 + 70	1845 x 225 x 240	C4-1816-3070
1825 x 165 x 95 + 70	1845 x 225 x 205	C4-1816-9570
1845 x 350 x 190 + 125	1880 x 400 x 345	C4-1835-9025
1845 x 350 x 90 + 65	1880 x 400 x 285	C4-1835-9065
1845 x 350 x 190 + 65	1880 x 400 x 285	C4-1835-9066
1845 x 350 x 190 + 195	1880 x 400 x 415	C4-1835-9095
1850 x 490 x 135 + 145	1910 x 555 x 310	C4-1849-3545
1830 x 775 x 155 + 165	1910 x 850 x 355	C4-1877-5565
1830 x 775 x 365 + 165	1910 x 850 x 565	C4-1877-6565
1830 x 775 x 365 + 375	1910 x 850 x 775	C4-1877-6575
1820 x 865 x 290 + 290	1880 x 930 x 600	C4-1886-9090
1995 x 235 x 80 + 60	2035 x 275 x 170	C4-1923-8060
1995 x 235 x 180 + 60	2035 x 275 x 270	C4-1923-8061
1995 x 235 x 180 + 185	2035 x 275 x 395	C4-1923-8085
2020 x 875 x 150 + 150	2080 x 930 x 340	C4-2087-5050
2020 x 875 x 150 + 80	2080 x 930 x 270	C4-2087-5080
2020 x 875 x 280 + 150	2080 x 930 x 470	C4-2087-8050
2020 x 875 x 280 + 80	2080 x 930 x 400	C4-2087-8080
2020 x 875 x 280 + 280	2080 x 930 x 600	C4-2087-8081



The amazing number of standard sizes increases permanently.



Unlimited stackability

Almost every container is, with same base area, stackable.

Regardless of integrated nubs or skids, of feet for fork-lift trucks or shock absorbers. They are stackable even if a trolley system is attached. A continuous stacking system for optimal land use.

Characterisation through polychromy

The optional polychromy arranges distinctiveness and better organization of storage, transport and logistic solutions.

This conspicuous and attractive design is available for several standard sizes. Regarding the different fields of application for your individual CARGO containers, please contact our KKC consultants.



Interior design with high material thickness

Better protection of the interior thanks to considerably higher foam material thickness. Due to the use of modern water jet cutting technology at KKC, considerable thicker foam plates could be handled.

Individual solutions for interior design

The extensive vertical range of manufacture as well as the orientation in metal construction allows besides conventional solutions for interior design the production of even complex mechanical restraint systems. For this purpose we offer interior design "made to measure".



Optimal protection thanks to individual foam fitting.

Protection and order in every transport container should be the uppermost command if professionalism dominates thinking and action. KKC offers not only an empty container. Our concept comprehends the entire logistic unity. Therefore KKC produces suitable, for every use of application individually designed foam fittings.



Interior design with low material thickness

Processing of low, high-tensile foam plates is carried out by our CNC-milling machines. When processing appropriate details, protection of the interior could be achieved cheaply with this handling.

Accurately fitting interior design for several parts

Individual adjustment is required if several individual components of one product group or different product variations should be placed in one CARGOBOX. KKC offers for this the option of the individual protection concept. With high-quality approved foams, CARGO containers will be padded individually.



Use of best materials.

Best "Made in Germany" quality by high efficiency thanks to use of best materials. Quality of the used standards of handle, lock, outer material and aluminium frame guarantees an optimal, ready for use product at high level.

In addition you have the option to choose many features individually and to optimize them for your intended use.

Contact your KKC experts.



Turning locks or rather butterfly locks

This extremely sturdy lock system tightens both case halves with a steel spring system and could be handled even with gloves.



Logistic with fork-lift truck

Trouble-free transport with appropriate stacking feet under the CARGOBOX. Appropriate details could be ordered optionally. With this, organizing your warehouse without any euro-pallets is possible.



Adjacent spring catches

Spring catches abut always on the casing. The padding is generous and makes carrying with or without gloves easier.



Pressure balance stabiliser

Pressure balance stabilisers or pressure compensating valves are used from protection class IP 54 (splash-proof) as per DIN EN 60529 and higher.



Permanent labelling

Permanent, non-volatile labelling will be realized during production. Standard letters allow a low-priced labelling for every container.



Retractable handles

Retractable handles in connection with corner rollers allow simple and easy transportation of the containers. When the handles are not used, they disappear in the box and could be extended when required.



Cargo - Standard Trolley

CARGO - TROLLEY

Standard sizes with integrated trolley solution

With the help of rollers and retractable handle, the sturdy carrying case becomes an easy to handle and mobile case. KKC offers various standard trolleys at different sizes.

Furthermore, many standard carrying cases could be equipped with a roller solution and retractable handles (for further information see pp. 16 - 22).

- 32 different standard sizes and 350 further sizes could be optionally equipped with rollers
- Stackable with same size
- Different trolley variations available
- Splash guard up to IP 65 (optional)
- Long-lasting, permanent reusability
- Resistant to chemical impacts
- Suitable for air freight according to ATA 300 code
- 8 standard colours are available

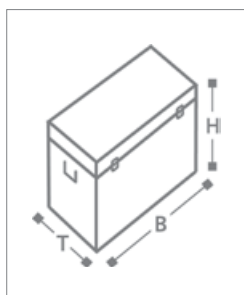

Cargo - Standard boxes with additional trolley function

The built-in corner rollers could be integrated harmonically in the case. They are used for nearly all standard sizes, as shown on the right side. The necessary bearing-load is considered when choosing and mounting it.



W/D/H (mm) Inside dimensions	W/D/H (mm) Outside dimensions	Article No.
485 x 425 x 185 + 125	560 x 480 x 385	CT-4842-8525
485 x 425 x 240 + 125	560 x 480 x 440	CT-4842-4025
485 x 425 x 185 + 190	560 x 480 x 450	CT-4842-8590
485 x 425 x 240 + 190	560 x 480 x 505	CT-4842-4090
510 x 430 x 160 + 55	560 x 475 x 275	CT-5143-6055
510 x 430 x 160 + 100	560 x 475 x 320	CT-5143-6000
510 x 430 x 215 + 55	560 x 475 x 330	CT-5143-1555
510 x 430 x 215 + 100	560 x 475 x 375	CT-5143-1500
510 x 430 x 300 + 55	560 x 475 x 420	CT-5143-0055
510 x 430 x 300 + 100	560 x 475 x 465	CT-5143-0000
510 x 430 x 360 + 55	560 x 475 x 480	CT-5143-6056
510 x 430 x 360 + 100	560 x 475 x 525	CT-5143-6001
590 x 515 x 175 + 120	655 x 565 x 375	CT-5351-7520
590 x 515 x 225 + 120	655 x 565 x 425	CT-5351-2520
590 x 515 x 175 + 190	655 x 565 x 445	CT-5351-7590
590 x 515 x 225 + 190	655 x 565 x 495	CT-5351-2590

W/D/H (mm) Inside dimensions	W/D/H (mm) Outside dimensions	Article No.
580 x 520 x 220 + 70	645 x 570 x 355	CT-5852-2070
580 x 520 x 220 + 130	645 x 570 x 415	CT-5852-2030
580 x 520 x 300 + 70	645 x 570 x 435	CT-5852-0070
580 x 520 x 300 + 130	645 x 570 x 495	CT-5852-0030
625 x 405 x 200 + 80	700 x 450 x 350	CT-6240-0080
625 x 405 x 260 + 80	700 x 450 x 410	CT-6240-6080
625 x 405 x 250 + 170	700 x 450 x 490	CT-6240-5070
625 x 405 x 260 + 210	700 x 450 x 540	CT-6240-6010
650 x 480 x 105 + 155	695 x 520 x 320	CT-6548-0555
650 x 480 x 145 + 155	695 x 520 x 360	CT-6548-4555
650 x 480 x 145 + 195	695 x 520 x 400	CT-6548-4595
655 x 505 x 235 + 70	730 x 555 x 375	CT-6550-3570
655 x 505 x 235 + 105	730 x 555 x 410	CT-6550-3505
655 x 505 x 285 + 70	730 x 555 x 425	CT-6550-8570
655 x 505 x 285 + 105	730 x 555 x 460	CT-6550-8505
700 x 580 x 125 + 150	800 x 635 x 340	CT-7058-2550

WATERPROOF-S

Unbreakable, waterproof transport cases
with lifelong guarantee



WATERPROOF-S



WATERPROOF-S

The waterproof and unbreakable cases made in the United States. Companies all over the world trust in these unbreakable cases - from the military to the oil and shipping industry up to the electrical industry and machine construction.

The large number of the available case sizes offers a solution for nearly every use of application. The waterproof casing made of polypropylene will be completed with professional foam fittings, produced at KKC.

Besides their extreme stability the cases are UV resistant and furthermore they are resistant to solvents. The cases could be used on land, on water and in the air thanks to the fully automatic 2-way pressure compensating valve.

Mobility and interior design are individually adaptable (see p. 51 and following pages).

W/D/H (mm) Inside dimensions	Colour	Article No.
234 x 180 x 75+30	black	421300.00
249 x 177 x 125+30	black	421301.00
305 x 229 x 76+38	black	421302.00
381 x 264 x 108+44	black	421303.00
406 x 254 x 89+50	black	421304.00
432 x 292 x 108+44	black	421305.00
470 x 330 x 82+38	black	421306.00
470 x 330 x 139+38	black	421307.00
520 x 292 x 159+50	black	421308.00
520 x 393 x 140+50	black	421309.00
558 x 432 x 153+50	black	421310.00

Solutions in detail.

The carrying handle is coated with a padding material and fits perfectly in hand. When folded down, the handle is locked into place and does not rattle during transport.

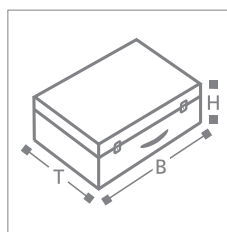

WATERPROOF-S



WATERPROOF-S with rollers

From a certain size on it is almost indispensable to arrange the transport of the products in the case comfortably and, with the help of roller systems, easily to handle.

Of course the roller systems which are used for the cases of the product line Waterproof-S with rollers are especially made for rough and tough use. The permanent functionality is the quality standard and guarantee for long-durability.



Mobility and interior design are individually adaptable (see p. 51 and following pages).

W/D/H (mm) Inside dimensions	Colour	Article No.
483 x 362 x 153+50	black	421350.00
520 x 292 x 140+50	black	421351.00
520 x 393 x 204+50	black	421352.00
558 x 432 x 217+50	black	421311.00
584 x 432 x 292+64	black	421353.00
737 x 457 x 292+64	black	421354.00
1080 x 368 x 102+38	black	421355.00
1282 x 368 x 114+38	black	421356.00



Cylinder lock as set for Waterproof-Cases

By changing the lock the case content can be protected against unauthorized access. The cylinder lock set is for self-installation and consists of 2 cylinders including clasp and 2 keys.



Cylinder lock as set	Article No.:	Suitable for Article No.:
Size 1	421399.00	421300, 421301
Size 2	421399.01	421302, 421305, 421306 421307
Size 3	421399.02	421399.02 421303, 421304, 421308, 421350, 421351, 421352, 421353, 421354, 421355, 421356



WATERPROOF-S

Case with individual foam fitting



Components production

Perfect protection of the valuable content by using individually designed foam components. In addition to the water tightness according to IP 65 there is the advantage of safety of all-round protection. Because of our diverse possibilities of foam processing every option is possible. Even up to branding or specific individualization.



PROFESSIONAL

Aluminium Frame Cases





PROFESSIONAL Cases

- Anodized aluminium frame extrusions
- Laminated surface in silver-grey Oslo No. 475 or stone-grey mandarin No. 472
- Automatic locks, chrome plated
- Handle with chrome ring
- Floating hinges, chrome plated
- Plastic foot studs
- Steel corners, chrome plated
- Laminated with synthetic foil

Mobility and interior design are individually adaptable (see p. 65 and following pages).

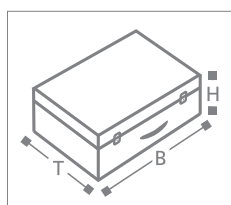

W/D/H (mm) Inside dimensions	Article No. Silver-grey	Article No. Stone-grey
345 x 255 x 85+40	71110.10	71110.20
385 x 235 x 65+40	71120.10	71120.20
420 x 310 x 90+40	71125.10	71125.20
460 x 340 x 115+40	71130.10	71130.20
520 x 390 x 125+50	71150.10	71150.20
595 x 395 x 135+50	71160.10	71160.20
650 x 410 x 180+50	71170.10	71170.20



PROFESSIONAL Box

- Anodized aluminium frame extrusions
- Laminated surface in silver-grey Oslo No. 475 or stone-grey mandarin No. 472
- Automatic locks, chrome plated
- Handle with chrome ring
- Floating hinges, chrome plated
- Plastic foot studs
- Steel corners, chrome plated
- Laminated with synthetic foil

Mobility and interior design are individually adaptable (see p. 65 and following pages).

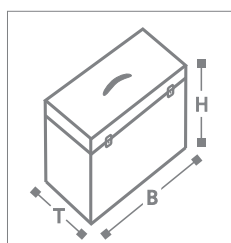

W/D/H (mm) Inside dimensions	Article No. Silver-grey	Article No. Stone-grey
325 x 130 x 180+40	75110.08	75110.20
405 x 210 x 200+50	75120.08	75120.20
450 x 260 x 275+50	75130.08	75130.20
486 x 275 x 340+50	75140.08	75140.20

PROFESSIONAL



10

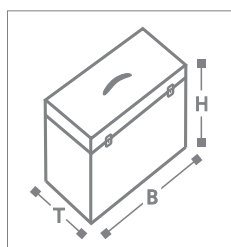

PROFESSIONAL Office-Roller

- Anodized aluminium frame extrusions
- Laminated surface in silver-grey Oslo No. 475
- Rollers, 150 mm diameter
- Retractable handle with swing mechanism
- Organisation tray in lid
- Partitioning compartment for hanging file system
- Adjustable compartments
- Removable plastic compartment for writing utensils

Adjustable interior compartments for use of all ring binders and / or hanging file systems. Compartments are fitted with adjustable dividers, e.g. for notebooks.

Thanks to the retractable handle, installed on the outside, the whole case capacity could be used. Even if the handle is pulled out, the lid could be opened without any problems.

	W/D/H (mm) Inside dimensions	Article No. Silver-grey
with rollers	402 x 215 x 300+50	71200.10

PROFESSIONAL



10

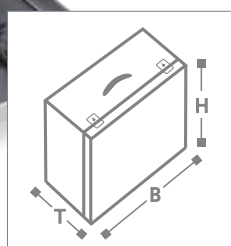

PROFESSIONAL Vendor-Roller

- Anodized aluminium frame extrusions
- Laminated surface in silver-grey Oslo No. 475
- Rollers, 150 mm diameter, and retractable handle
- Fitted with 3 drawers, each 40 mm high and 4 drawers, each 60 mm high
- Drawers separately removable, the inside base is padded with 5 mm foam
- Inside drawer dimensions 370 x 220 mm

Individual design of drawers with foam, dividing wall system, compartments for small items and deep recessed inserts.



	W/D/H (mm) Inside dimensions	Article No. Silver-grey
with rollers	410 x 290 x 400	71201.10

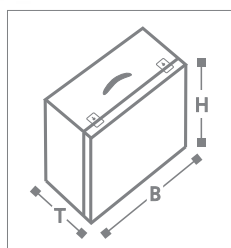

PROFESSIONAL Flex-Vendor-Roller

- Anodized aluminium frame extrusions
- Laminated surface in silver-grey Oslo No. 475
- Rollers and retractable handle
- Individually equipped with drawers. Could be equipped with 15 drawers at most.

Drawers and foam are not included in the basic case and have to be ordered separately.

- Drawers separately removable
- Inside drawer dimensions 378 x 250 mm

	W/D/H (mm) Inside dimensions	Article No. Silver-grey
with rollers	410 x 290 x 400	71301.10

Individual design of drawers with foam and deep recessed inserts.



Drawers and standard foam inserts for Flex-Vendor-Roller

Foam Inserts

Article No.	Type	Cut-outs	Cut-out dim. W x D x H in mm	Foam height mm
645329	1 HE	30 (writing utensils)		
645330	1 HE	12	80 x 66 x 18	20
645331	1 HE	4	80 x 66 x 18	20
		4	170 x 66 x 18	20
645332	2 HE	12	80 x 66 x 35	40
		4	80 x 66 x 35	40
645333	2 HE	4	170 x 66 x 35	40
		4	170 x 66 x 35	40
645334	3 HE	6	100 x 100 x 65	70
645335	3 HE	2	100 x 60 x 65	70
		4	100 x 100 x 65	70
		1	200 x 80 x 65	70

Drawers

Article No.	Type	Material Handle	Dimensions mm W x L	Height mm
645326	1 HE	Aluminium Knob	378 x 250	21
645327	2 HE	Aluminium Knob	378 x 250	48
645328	3 HE	Aluminium Knob	378 x 250	72

PROFESSIONAL Individual

With this product line almost every solution is possible.

Variety is achieved through individual design and the implementation of a wide choice of roller systems.

Further information could be found on pages 51 to 70.



K Case, laminated surface in Anthracite 551 (in the background: silver-grey Oslo 475), in lid nap foam and on bottom a die-cut foam insert.



U Uniport, laminated surface black mandarin. Document pouch and measuring instrument holders in lid. Case body lined with black powder-coated metal board, equipped with compartments for measuring devices. There are metal drawers below for accessories. Holding straps for further measuring instruments are mounted inside the front louvre.

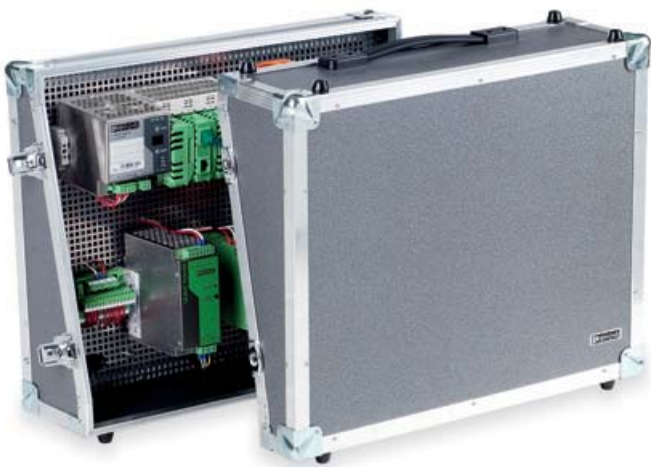

X X-Case, laminated surface in Anthracite 551. Case is made of two identical shells, cut in console form. Mounting plates are integrated in case interior to affix test circuits.



X X-Case, laminated surface in Anthracite 551. Attaché insert in lid for documents and tools, in bottom there is a mounting plate. Power connections are built into side wall as well as an ergonomically designed front plate with various mounting possibilities for devices.



S **PROFESSIONAL** Shopper PROFI

The uses of the Shopper System are limitless. Shopper Systems are manufactured with highest accuracy. This ensures that all shopper elements fit perfectly together. This applies even to shopper elements which are bought some years later.

The standard system consists of several elements which could be combined individually. The standard interior decoration could be kept very flexible and from 10 same elements on, it could be equipped individually, e.g. with milled foam inserts.

The shopper system is perfect for your sales activities. There are, in the warehouse, car or van, various layers equipped with different materials ready for use. They will be individually packed for each case of application. This enables high flexibility and long-term benefits. Because of the comfortable 150 mm rollers the PROFI system is very mobile for nearly every area.



A pleasurable handling is due to the flexibility and rigidity of the retractable handle which is installed on the backside. Thanks to the installed skids you can get over stairs without having to carry the system. Any layers could be stacked thanks to the mounting on the lowest part. The lid forms the top of the system. Together with the lid one or two layers could be transported without the base part.

Drawing with individual modification



Lid H = 20 mm



Middle part H = 70 mm



Middle part H = 100 mm



Middle part H = 150 mm

 Base part H = 320 mm
with office equipment

PROFESSIONAL Shopper PROFI

Compile your Shopper PROFI individually. All parts are individually combinable. A complete system consists at least of base part, any middle part and lid.

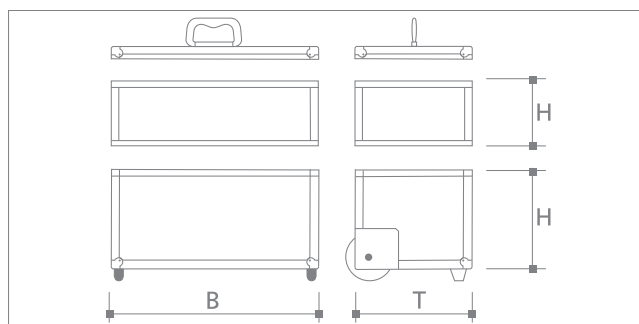

Type	W/D/H (mm) Inside dimensions	Article No.
Lid	450 x 300 x 20	71401.00
Middle part H70	450 x 300 x 70	71404.00
Middle part H100	450 x 300 x 100	71403.00
Middle part H150	450 x 300 x 150	71402.00
Base part H320	450 x 300 x 320	71400.00
Equipment Office for base part	450 x 300 x 320	71406.00

All middle and base parts are equipped with foam pads and each with 2 dividing walls which can be combined as required.

As an alternative you could choose the office equipment with hanging file system and dividing walls which can be combined as required.



Office - Equipment

If you order 10 or more shopper systems, we will manufacture the shopper system PROFI individually according to your specifications, even regarding the size.



S PROFESSIONAL Shopper BASIC

In contrast to the shopper system PROFI, the shopper system BASIC has very compact dimensions. The decision for the one system or the other system is only the result of the case of application.

The standard system BASIC consists of several individually combinable elements. The standard interior decoration could be kept very flexible and from 10 same elements on it could be kept individually, e.g. with milled foam inserts.

The shopper system BASIC is perfect for your sales activities. There are, in the warehouse, car or van, various layers equipped with different materials ready for use. They will be individually packed for each application. This enables high flexibility and long-term benefits.

Because of the comfortable 80 mm rollers the system is very mobile for nearly every area.



A pleasurable handling is due to the flexibility and rigidity of the retractable handle which is installed on the backside. Thanks to the installed skids you can get over stairs without having to carry it. Any layers could be stacked thanks to the mounting on the lowest layer. The lid forms the top of the system. Together with the lid one or two layers could be transported without the base part.

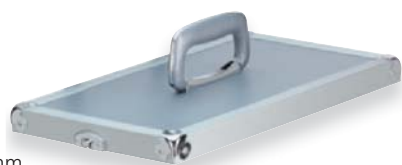

Lid H = 20 mm



Middle part H = 70 mm



Middle part H = 100 mm



Middle part H = 150 mm

 Base part H = 300 mm
with office equipment

PROFESSIONAL Shopper BASIC

Compile your Shopper BASIC individually. All parts are individually combinable. A complete system consists at least of base part, any middle part and lid.

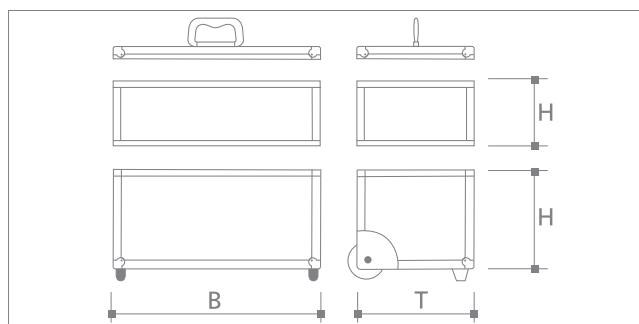

Type	W/D/H (mm) Inside dimensions	Article No.
Lid	380 x 220 x 20	71450.00
Middle part H70	380 x 220 x 70	71451.00
Middle part H100	380 x 220 x 100	71452.00
Middle part H150	380 x 220 x 150	71453.00
Base part H150	380 x 220 x 150	71454.00
Base part H300	380 x 220 x 300	71455.00
Equipment Office for base part H300	380 x 220 x 300	71456.00



Base part H = 150 mm

The padded base part H150 is equipped with two dividing walls which can be combined as required. The padded base part H300 offers with the arbitrary supplementary office equipment space for a hanging file system and folders in A4 format.

PROFESSIONAL Hardware Variations

Locks

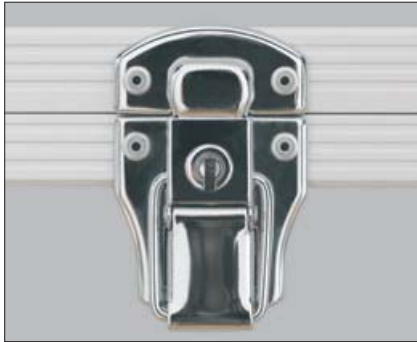

Art.-No. 620241: Automatic lock, chrome, with key



Art.-No. 620203: Automatic lock, silver mat, with key



Art.-No. 620257: Automatic lock, black, with key

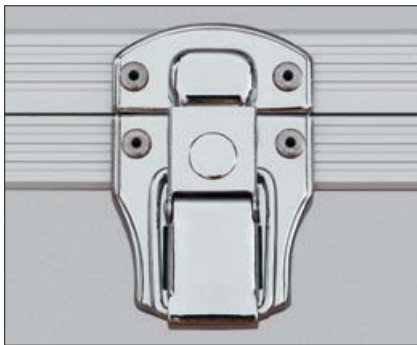

Art.-No. 620231: Automatic lock, chrome, without key

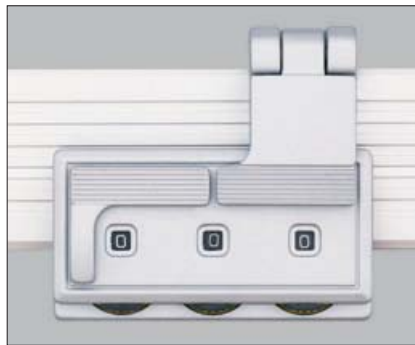

Art.-No. 620074: Combination lock, silver-grey

Hinges

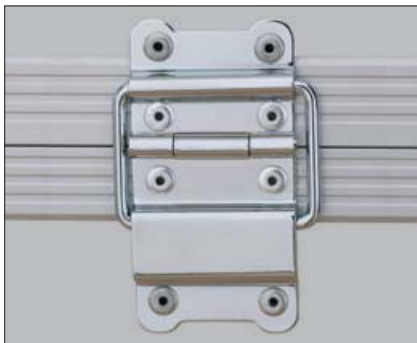

Art.-No. 620244: Floating hinge, chrome, 8-hole, opening 93°

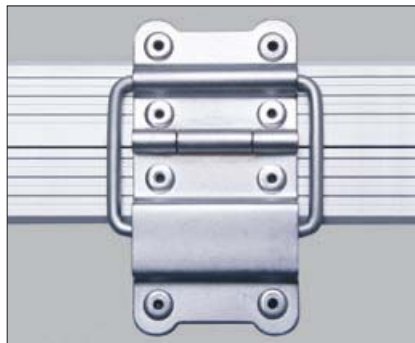

Art.-No. 620208: Floating hinge, silver mat, 8-hole, opening 93°



Art.-No. 620098: Floating hinge, black, 8-hole, opening 93°



Art.-No. 620247: Floating hinge, chrome, 8-hole, strengthened, opening 93°



Art.-No. 620262: Detachable hinge, chrome, opening 180°



Art.-No. 620152: Pin hinge, chrome, detachable, opening 180°

All pictured hinges in the PROFESSIONAL product line are available for custom-made productions.

Handles



Art.-No. 620017: Handle Highline, glossy



Art.-No. 620018: Handle Highline, mat



Art.-No. 620298: Handle round, grey



Art.-No. 620246: Handle round, black

PRO WORKS / FLIGHT

Aluminium Tool Cases / Airworthy





PRO WORKS Aluminium Cases

Sturdy aluminium case for special use.

The case that fits for every work area and is individually designed for you: as a tool- or service case, for measuring instruments or as a programming case; in the classical form or with modern opening angles, with special compartments or with rollers. Pro Works meets each and every need and protects everything in it. For sure!

Colours for individual identification.

With orders of 10 or more the cases are available in the colours below with a sturdy structured surface:

- Violet
- Yellow
- Blue
- Red
- Green
- Black

Stability "Made in Germany".

The Pro Works body is a sturdy unity of anodized aluminium built in a sandwich-type construction. The material is highly resistant, holding up to extraordinary hard use. Solid chromed steel corners with integrated foot studs serve for stability and extra protection. The extreme abrasion-proof, water-proof, and sturdy surface resists acids, solvents, oil, heat and cold.

Easy-to-operate automatic locks combined with robust hinges serve for long-term use in the most rugged of conditions.

Equipped with carrying strap, tool charts and useful details, Pro Works definitely reflects its symbol of quality - "Made in Germany".

Strap and shoulder pads ergonomically designed

The carrying strap is made of tear-proof webbed material with shoulder pads and two easy-to-operate clasps. Two metal loops are included as a standard feature. If the strap is included in delivery, metal loops are mounted on sides.



Model	Adjustable range (mm)	Article No.
Carrying strap	88 – 1400	80930

PRO WORKS Tool Case BASIC

- Top quality tool case, handy, sturdy, practical for a variety of assignments
- Features include additional document holder in lid and / or a second tool board
- Double sided tool panel No. 3, removable and replaceable with simple turning locks
- Shell of the tool case is covered with a useful tool panel to prevent small items from falling out
- Adjustable dividers in base part of case maintain constant tool assortment



Included in delivery:

BASIC Star

- 1 tool tray
- 1 tool panel No. 1
- 1 tool panel No. 3
- 1 document panel
- 1 carrying strap

BASIC A

- 1 tool tray
- 1 tool panel No. 1
- 1 tool panel No. 3
- 1 carrying strap

BASIC B

- 1 tool tray
- 1 tool panel No. 3
- 1 carrying strap



Model	W/D/H (mm) Inside dimensions	Article No.
BASIC Star	460 x 320 x 170	80610.00
BASIC A	460 x 320 x 170	80611.00
BASIC B	460 x 320 x 170	80612.00

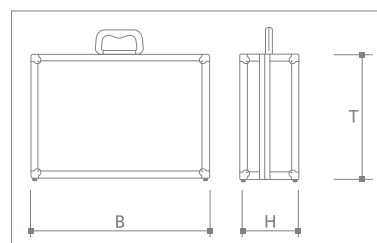

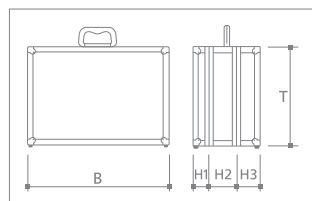

Model	W/D/H ₁ +H ₂ +H ₃ (mm) Inside dimensions	Doc.- panel	Article No.
ALPHA Star	460 x 327 x 90+90+60	yes	80510.00
ALPHA	460 x 327 x 90+90+60	no	80511.00
ALPHA Star Sorti	460 x 327 x 80+90+60	yes	80513.00
ALPHA Sorti	460 x 327 x 80+90+60	no	80514.00
organ. tray size 1	54 x 54 x 63		640014
organ. tray size 2	108 x 54 x 63		640015
organ. tray size 3	108 x 108 x 63		640016
organ. tray size 4	162 x 108 x 63		640017

PRO WORKS ALPHA

The innovative PRO WORKS ALPHA

Here's the creative solution to easily access all your tools with two separate lids and inner compartments. With practically in mind this case allows complete separation of contents, e.g. tools on top and small items below or tool on top and your notebook below. Both case halves can be custom designed according to your needs.

An individually designed tool panel separates case halves but can be removed in seconds with turning locks. Variations are unlimited when planning the two tool shells due to dividers and small compartment trays in the bottom. A one-sided tool panel acts as a cover to ensure none of those small items fall out. Alternative: Foam padding in separate bottom part for delicate instruments.

"Sorti Cases" are tightly fitted with a special foam padded, closed sorting tray. Tool case and small item assortment tray are considered one unit.

Included in delivery:

ALPHA

- 1 tool tray
- 1 tool panel No. 3
- 1 carrying strap, foam padding in base part

ALPHA Sorti

- 1 tool tray
- 1 tool panel No. 3
- 1 carrying strap
- 12 organisation trays size 1
- 6 organisation trays size 2
- 3 organisation trays size 3
- 2 organisation trays size 4

ALPHA Star

- 1 tool tray
- 1 tool panel No. 3
- 1 document panel
- 1 carrying strap, foam padding in base part

ALPHA Star Sorti

- 1 tool tray
- 1 tool panel No. 3
- 1 document panel
- 1 carrying strap
- 12 organisation trays size 1
- 6 organisation trays size 2
- 3 organisation trays size 3
- 2 organisation trays size 4

PRO WORKS Shopper

The tool case and spare parts storage at hand.

Transporting and storing your items is optimal because you have created the case just for your needs. Whether it's measuring instruments and accessories, tools and spare parts or tiny items - you decide what is necessary for the assignment. Everything else is left in the car or at home base.

Three elements with practical inside height of 60 mm, 80 mm and 100 mm are available. The sides are lined with notched foam. The dividers slide into slots. The bottom is lined with foam padding.

The order of all SHOPPER elements can be combined according to choice.

For further information see page 26.

Included in delivery:

Shopper H6 (inside height 60 mm)
2 dividers

Shopper H8 (inside height 80 mm)
2 dividers

Shopper H10 (inside height 100 mm)
2 dividers





PRO WORKS SHOPPER Sorti

The Pro Works SHOPPER Sorti is the fourth element of the available Shopper stacking system. In order to make taking those small items easier, we have fitted the Shopper Sorti with special sorting trays. In this element a foam panel comes as standard feature. This is fitted into the Shopper lid or under the next element below. This ensures that the sorting trays are safe and tightly closed.

Included in delivery:

SHOPPER Sorti

- 8 organisation trays size 1
- 4 organisation trays size 2
- 2 organisation trays size 3
- 2 organisation trays size 4
- 1 foam panel

The base element of the SHOPPER is fitted with either 4 controllable rubber rollers or foot studs according to your choice and has a useful inside height of 150 mm. Naturally we use our steel corners with integrated foot studs for solid placement.

Included in delivery:

SHOPPER

- 2 dividers
- 1 lid

Organisation trays can be purchased separately (please refer to chart below).

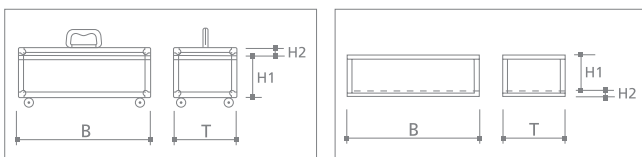

Model	W/D/H ₁ +H ₂ (mm) Inside dimensions	Article No.
SHOPPER with rollers	486 x 220 x 150+20	80210.00
SHOPPER without rollers	486 x 220 x 150+20	80211.00
SHOPPER Sorti	486 x 220 x 81	80215.00
SHOPPER H6	486 x 220 x 81	80214.00
SHOPPER H8	486 x 220 x 101	80213.00
SHOPPER H10	486 x 220 x 121	80212.00
Lid	486 x 220 x 20	80216.00
Organisation tray size 1	54 x 54 x 63	640014
Organisation tray size 2	108 x 54 x 63	640015
Organisation tray size 3	108 x 108 x 63	640016
Organisation tray size 4	162 x 108 x 63	640017
Divider H6	220 x 60	80220
Divider H8	220 x 80	80219
Divider H10	220 x 100	80218
Divider Shopper	220 x 150	80217

PRO WORKS DUO Star

The star among the tool cases with many advantages. The DUO Star makes its mark with a completely new concept. When the automatic locks are unlocked, both v-shaped case halves stand alone. Every tool is readily accessible. The DUO Star comes with 4 double sided tool panels; each case side is equipped with 2 tool panels. Because of the arrangement each tool can be quickly seen and accessed. The case is set down in an upright position, just as it was carried. It's opened in this same position and laying the case flat on the floor and bending down for taking out tools is dispensed with this.

Included in delivery:

DUO Star

- 2 tool panels No. 1
- 1 tool panel No. 2
- 1 tool panel No. 3
- 1 carrying strap

Model	W/D/H (mm) Inside dimensions	Article No.
DUO Star	486 x 218 x 410	80110.00

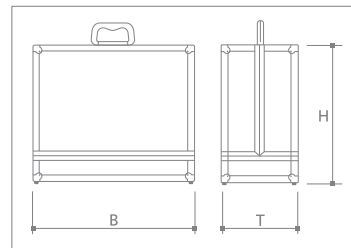

PRO WORKS Individual

Combination possibilities

The DUO Star could be combined with the SHOPPER system. With this combination far more space is attained. The DUO Star can be securely attached to the SHOPPER elements. This now allows the case to be mobile. On even grounds, in production halls, on large construction sites and in administration buildings this combination case goes effortlessly wherever you do. If rolling the case is no longer possible, you simply detach the SHOPPER and replace the lid. Now you have two cases that can be carried in the conventional way. The real advantage of the combination DUO Star / SHOPPER is that the contents are accessible without separating the two. Because of the height the tools are easily accessed without bending down. Due to technical reasons the DUO Star cannot be directly connected to the SHOPPER Sorti. To achieve this, an additional third element must be placed in between.



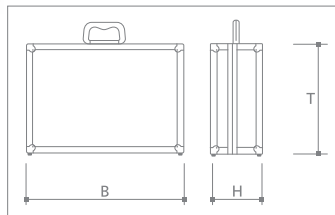

PRO WORKS FLIGHT Star BASIC

High quality tool case, airworthy, all-purpose and has repeatedly proven as indispensable.

- Depending on the model either a document panel and / or a second tool panel is built-in in the lid
- Double sided tool panel No. 3 which can be removed with turning locks and easily replaced
- The tool shell is covered with a double sided tool panel to ensure that small items remain in place
- Recessed locks and handles endure all transportation. An additional padlock secures the case's content completely (not included in delivery)

Included in delivery: FLIGHT Star...

BASIC S	BASIC A	BASIC B
1 tool tray	1 tool tray	1 tool tray
1 tool panel No. 1	1 tool panel No. 1	1 tool panel No. 3
1 tool panel No. 3	1 tool panel No. 3	
1 document panel		

Model	W/D/H (mm) Inside dimensions	Article No.
FLIGHT Star BASIC S	460 x 320 x 205	102480.00
FLIGHT Star BASIC A	460 x 320 x 205	102480.01
FLIGHT Star BASIC B	460 x 320 x 205	102480.02



PRO WORKS FLIGHT Star ALPHA

- A tool panel is built-in in the lid and depending on the model a document panel is also built-in
- Tool panel can be removed with turning locks and easily replaced
- In the centre section of the case there is a tool panel with variable dividers. It is covered with a one-sided tool panel
- The bottom of the case is lined with foam which ensures safe transportation of measuring instruments, notebooks, circuit boards and countless other delicate items

Included in delivery:

FLIGHT Star ALPHA S

- 1 tool tray
- 1 tool panel No. 3
- 1 document panel

FLIGHT Star ALPHA

- 1 tool tray
- 1 tool panel No. 3

PRO WORKS FLIGHT



5

PRO WORKS FLIGHT Star ALPHA

The cases "PRO WORKS ALPHA Star Sorti" and "PRO WORKS ALPHA Sorti" are in addition equipped with assortment trays in the base part. The assortment trays are tightly closed with foam padding. Aside from this "PRO WORKS ALPHA Star" and "PRO WORKS ALPHA" are identical. With these two models the tool case and small item tray are assembled as one unit.

Included in delivery:

FLIGHT Star Sorti S

- 1 tool tray
- 1 tool panel No. 3
- 1 document panel
- 12 organisation trays size 1
- 6 organisation trays size 2
- 3 organisation trays size 3
- 2 organisation trays size 4

FLIGHT Star Sorti

- 1 tool tray
- 1 tool panel No. 3
- 12 organisation trays size 1
- 6 organisation trays size 2
- 3 organisation trays size 3
- 2 organisation trays size 4

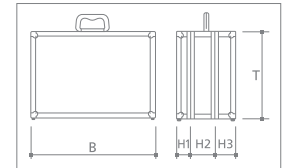

Model	W/D/H ₁ +H ₂ +H ₃ (mm) Inside dimensions	Article No.
FLIGHT Star ALPHA S	460 x 327 x 130+95+60	102480.03
FLIGHT Star ALPHA	460 x 327 x 130+95+60	102480.13
FLIGHT Star Sorti S	460 x 327 x 130+95+60	102480.04
FLIGHT Star Sorti	460 x 327 x 130+95+60	102480.14
Organ. tray size 1	54 x 54 x 63	640014
Organ. tray size 2	108 x 54 x 63	640015
Organ. tray size 3	108 x 108 x 63	640016
Organ. tray size 4	162 x 108 x 63	640017

PRO WORKS FLIGHT



5

PRO WORKS FLIGHT Star DUO S

The star among the tool cases with many advantages. The DUO star makes its mark with a completely new concept. When the turning locks are opened, both v-shaped case halves stand alone. Every tool is readily accessible. The DUO S comes with 3 double sided tool panels. Because of the arrangement each tool can be quickly checked and accessed. The case is set down in an upright position just as it was carried. It's opened in this same position and laying the case flat on the floor and bending down for taking out tools is dispensed with this. This tool case opens into two identical v-shaped halves and is designed to be combined with the SHOPPER system. The maximum opening angle of both sides to each other is 95°.

Included in delivery:

FLIGHT Star DUO S

- 2 tool panels No. 1
- 1 tool panel No. 2
- 1 tool panel No. 3

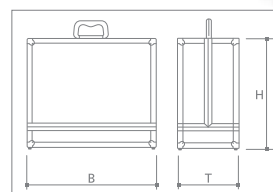

Model	W/D/H (mm) Inside dimensions	Article No.
FLIGHT Star DUO S with rollers	484 x 218 x 410	102500.00
FLIGHT Star DUO S without rollers	484 x 218 x 410	102500.01



PRO WORKS FLIGHT Star DUO S with SHOPPER

The DUO S is designed to be combined with the SHOPPER system. When more room is needed the SHOPPER system is the answer. The DUO S can be neatly attached to the SHOPPER elements. When doing this, the case becomes mobile. On even grounds, in production halls, on large construction sites and in administration buildings this combination case goes effortlessly wherever you do. If rolling the case is no longer possible, you simply detach the SHOPPER and replace the lid. Now you have two cases that can be carried in the conventional way.

The real advantage of the combination DUO Star / SHOPPER is that the contents are accessible without separating the two. Because of the height the tools are easily accessed without bending down.

Due to technical reasons the DUO S cannot be directly connected to the SHOPPER Sorti. To achieve this, an additional third element must be placed in between.

PRO WORKS Tool Panel



Panel No. 1
Article No. 530040

Front side:
Pouches



Back side:
Fastening straps
and pouches



Panel No. 2
Article No. 530041

Front side:
Pouches

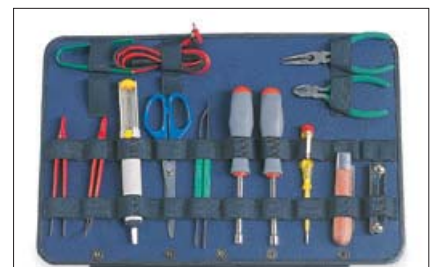

Back side:
Fastening straps



Panel No. 3
Article No. 530042

Front side:
Pouches



Back side:
Pouches

Features

Mounting forms, technique and accessories



Structural shapes



S Shopper



R Rack



X X-Case



K Case



B Box



U Uniport



H Hood

Structural Shapes

Mechanical drawings or schematic diagrams are one thing. In conjunction with the reality, technique is sometimes easier to explain. For a better understanding of the structural shapes, we have faced some real examples.

Structural Shapes

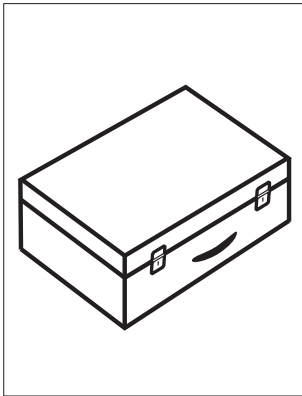

K Case

This all-purpose case has a short production time. Individual solutions are possible on short notice.

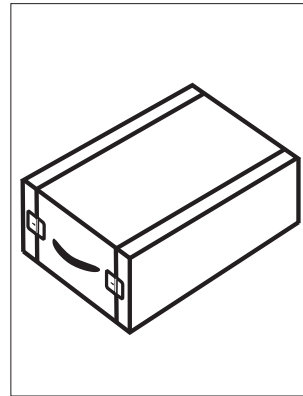

R Rack

The rack is the professional solution for transportation of measuring devices, either padded on all sides with foam or with an integrated front panel.

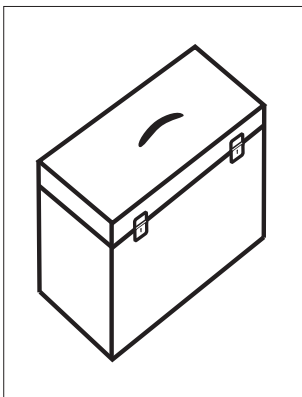

B Box

The box is ideal for transporting high or tall products, with fewer bottom area and necessary height.

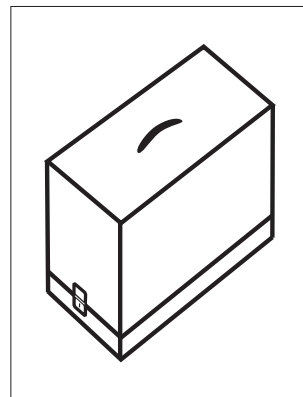

H Hood

The hood is ideal for presentation contents. Completely protected from all sides, but totally accessible once removed. Especially functional for heavy equipment.

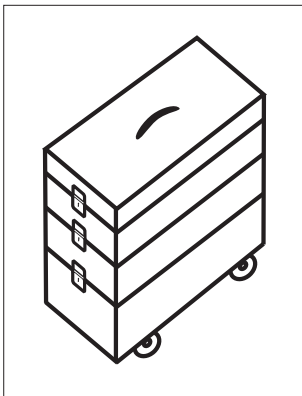

S Shopper

The shopper has optimal flexibility for presentation / vendor uses with its foam inserts which can be individually formed to perfectly fit instruments and measuring equipment.

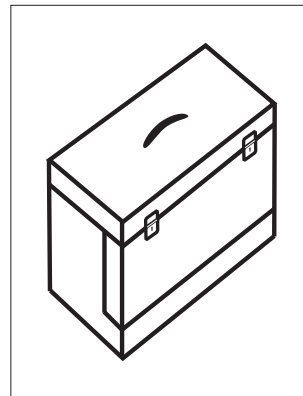

U Uniport

The uniport is the perfect mix of case and box. Often preferred for measuring instruments or complex presentation uses. After opening the lid another front hatch offers even more accessibility to the contents.

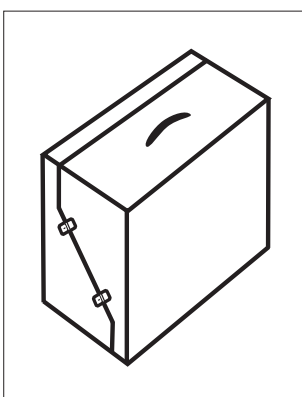

X X-Case

The x-case is the answer for the podium form presentation system. With two identical V-shaped halves this becomes the optimal presentation set.

Mobility and Handle Systems for Boxes

B1

Retractable handle, permanently mounted on exterior.

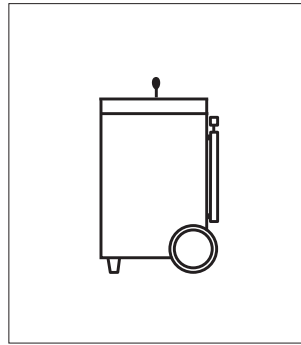
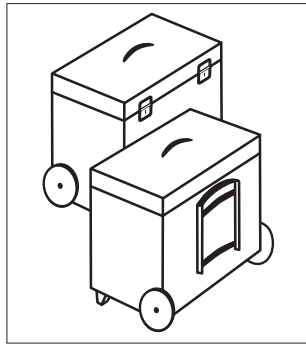

B1

Rollers 150 mm wide with rubber gripping surface for optimal comfort even on uneven grounds. Retractable handle mounted permanently on side of case.

B2

Retractable handle, mounted in pivoting exterior mechanism.

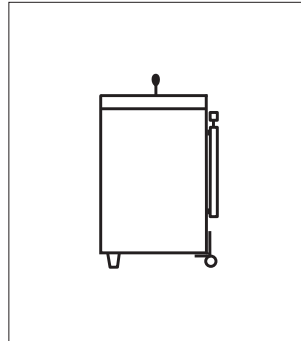
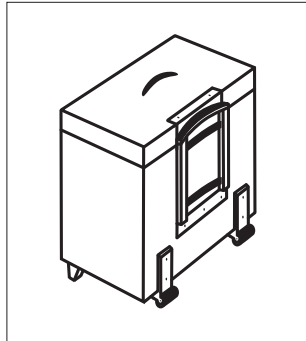

B2

Corner rollers 40 mm mounted on exterior.

B3

Built-in retractable handle, permanently mounted.

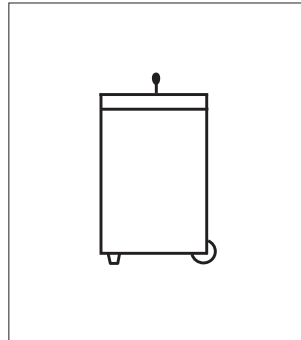
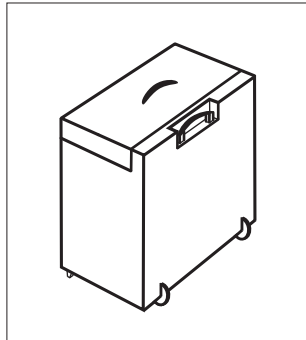

B3

Built-in inliner wheels. Inconspicuously integrated with smooth rolling feature.

Handle systems B1 - B3 are able to be individually combined with roller systems B1 - B3.

B4 **B4**

Trolley, retractable handle with integrated rollers. Removable with quick release lock. Mounted on back side of case.

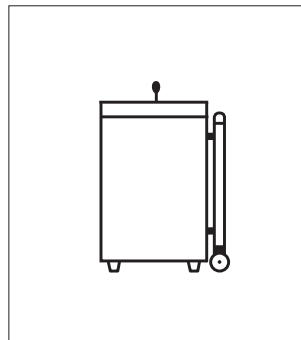
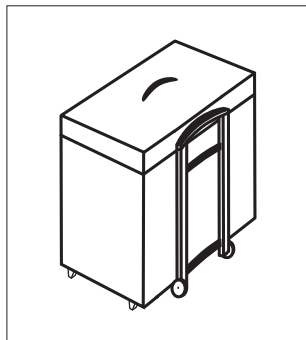

B5 **B5**

Trolley, retractable handle with integrated rollers. Removable with quick release lock. Mounted on bottom of case.

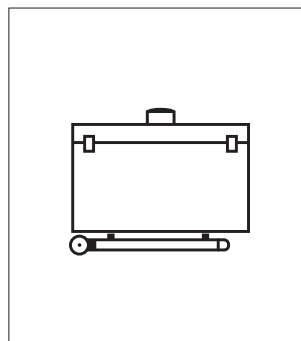
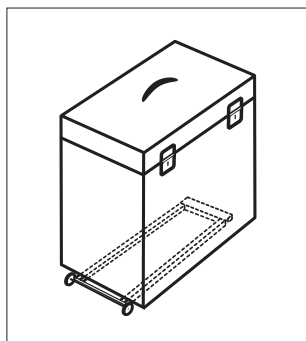

Mobility and Handle Systems for Cases



Built-in retractable handle, permanently mounted. Due to compact construction, minimal space inside the case is lost.

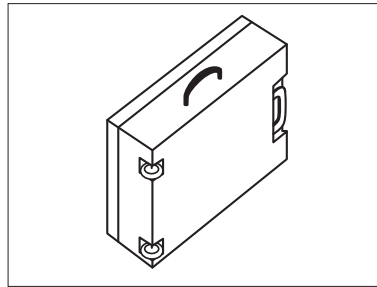

Built-in inliner wheels. Inconspicuously integrated with smooth rolling feature.



Retractable handle, permanently mounted on exterior. The affordable handle solution to retain usable space in the case.

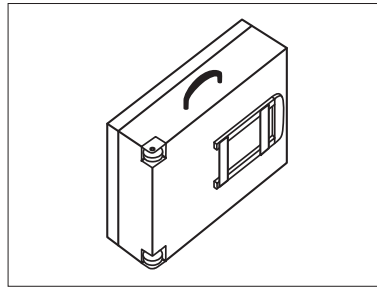

Built-in corner rollers 50 mm.



Retractable handle, permanently mounted on exterior. The affordable handle solution to retain usable space in the case.

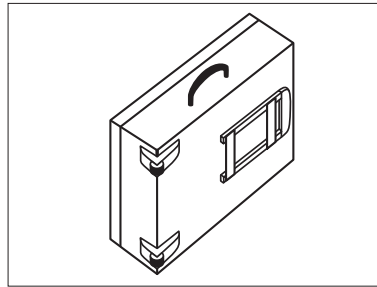

Corner rollers 40 mm.



Retractable handle, permanently mounted on exterior. The affordable handle solution to retain usable space in the case.

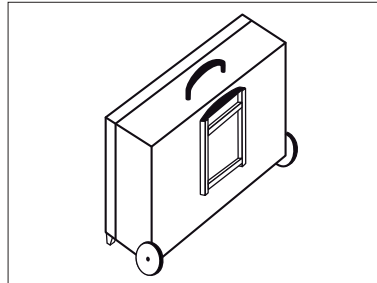

Rollers, 150 mm wide, with rubber gripping surface for optimal comfort even on uneven grounds.



Retractable handle, permanently mounted on exterior. The affordable handle solution to retain usable space in the case.

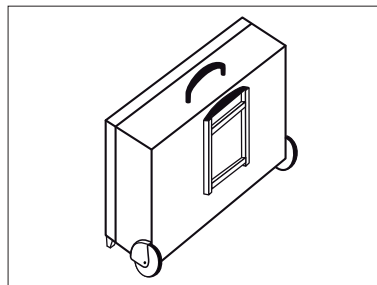

Attached rollers with "fenders" - die-cast housing, roller diameter 80 mm. Designed for use with heavy contents. Especially sturdy construction.

Handle systems K1 and K2 are able to be individually combined with roller systems K1, K2, K4, K5 and K6.



Trolley, retractable handle, mounted on exterior. Removable with quick-release lock.

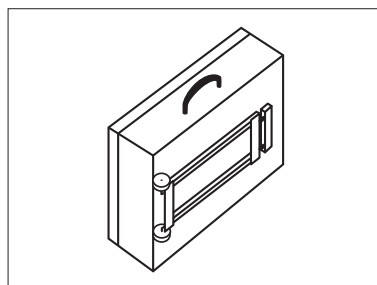

Surfaces and Colours



Standard, flexible or individual.

For each of the production lines we offer a wide variety of surfaces and material with standard cases. Within the framework of the designated range of surfaces, complete flexibility is possible.

With an eye for detail and your satisfaction as our goal, we'll always find the surface and colour solution that meets your every expectation.

With the understanding or the minimum quantity order, we "bend over backwards" to comply with your wishes.



Light-weight building board

for PROFESSIONAL, PROWORKS, PROWORKS FLIGHT

The special light-weight honeycomb panel made of polypropylene is the ideal material to save on weight with larger cases, yet remains enormously sturdy.

Light-weight building board, Light-weight building board
black grey



Surfaces and Colours - for CARGO

HDPE - Polyethylene plastics

This extreme robust and impact resistant plastic plate allows producing robust and break-proof transport packaging.

8 colours are available as standard.

You could choose the colour for each box. This prevents confusion in day-to-day business.

Dichroism

This is feasible for some sizes (please ask for further information) and offers very interesting solutions for reusable packaging.



Silver-grey

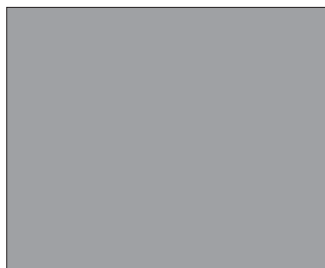

Red



Blue



Anthracite



Black



Yellow



Olive-green



White



Surfaces and Colours - for PROFESSIONAL, PRO WORKS, PRO WORKS FLIGHT



Laminate

Durable, attractive cases thanks to multi-layers of laminated surfaces. Perfect for robust, demanding jobs. Long-lasting and resistant to acids, oil and heat due to the use of multi-layered epoxy resin materials.



Mandarin, Red No. 431



Mandarin, Yellow No. 860



Mandarin, Green No. 450



Mandarin, Blue No. 851



Mandarin, Grey No. 472



Mandarin, Black No. 421

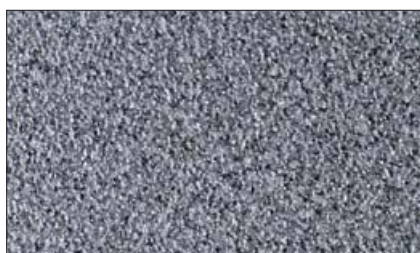

Mandarin, Anthracite No. 551



Oslo, Black No. 421



Oslo, Silver-grey No. 475

Interior Design

The coordinated inner features turn a case into a professional instrument for daily use. Smooth foam protects valuable content. We have precisely the right material for every possible requirement.

For optimal application in cases only two quality materials are used: Soft foam (EF) and rigid foam (PZ/LD).

Soft foam

Pliable foam from Polyurethane (PU) with a soft feel, e.g. nap foam is ideal for case padding and is relatively affordable in bulk purchase.

The colours range increment from light to dark-grey. Standard thicknesses are 20 / 30 / 40 mm.

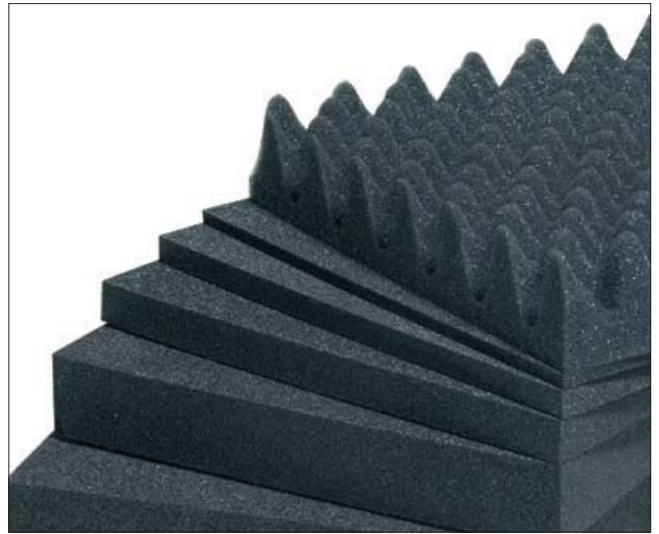

Rigid foam

The dense cellular, fine-poured foam made of plastazote (PZ) is ideal in presentation solutions because of its firmness.

By use of water-jet, milling or die-cutting, all of your products will rest securely in an exactly cut form. Colours in black, light-grey and light-blue offer many possibilities.

Standard PZ thicknesses are: 5 / 10 / 15 / 20 / 30 / 40 / 50 / 60 mm. Additional thickness can be attained by laminating layers of foam.

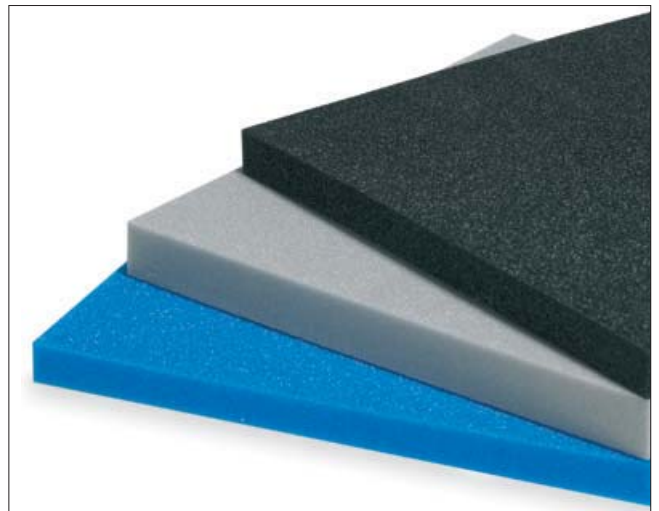

Notched foam

This specialised foam worked in panels with pre-cut notches is the perfect solution for variable dividers in cases. Increments of 15 mm allow you to design the compartments of your case to your individual needs. If necessary the size and depth of increments can be altered.



Processing of Foam



Milling

Complete 3-dimensionality of the cut-outs can be achieved in one operation. Rigid foam pads are the inserts' basic material. The individual profile of the cut-outs is computer programmed and guided. Even different heights and depths are no problem within one cut-out. The programmed form can be identically repeated at any time.

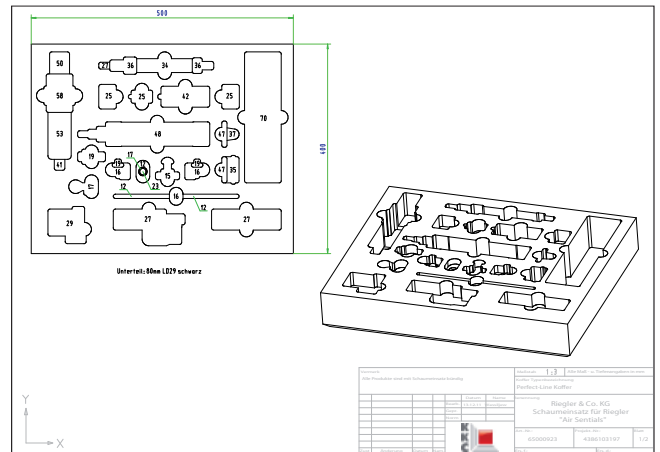

Several incoming parts simulate the contour of the cut-outs. With the help of CAD programs the profile of all cut-outs will be identified. The ideal order of products or rather of cut-outs results from the CAD drawing.

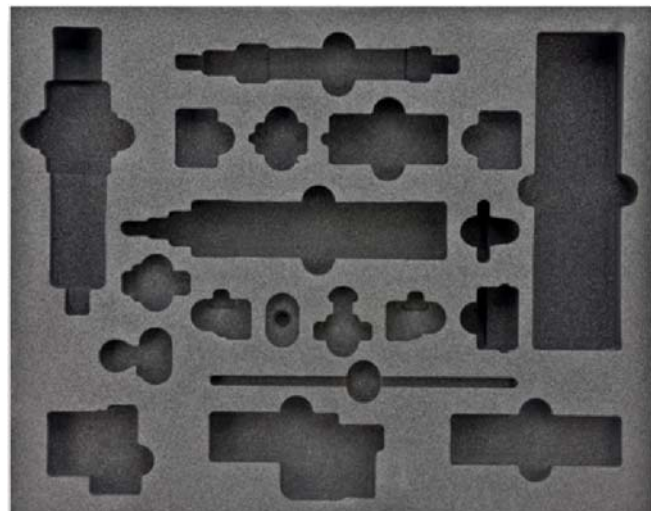

The CNC-milling machine carves out the profile of the foam according to drawing. This form of insert can be identically repeated in bulk quantities. Quality remains the same.

Technology and Processing

Laser Engraving

The used machines make the direct labeling of the foams' surfaces possible. With this you will get the perfect product presentation as basis for a successful selling process.



Two-coloured milled foam insert



Water-Jet Cutting

Absolute precision is achieved with water-jet cutting. Sharp, gentle or round profiles are perfectly formed. The different heights are achieved by craftsmanship.



Form Cutting

The professional and of good value processing of flexible foam. Additional refining can be applied with flocking.



Deep Recessed Inserts



Deep recessed inserts are an affordable alternative to foam. Despite the one-time machine set-up costs the unit costs can be kept low. When stability is needed for heavy tools or easy cleaning is required for presentation, this is the answer.

Deep recessed inserts with smooth PVC

Deep recessed inserts of smooth, indelible PVC are the perfect solution when cleaning is necessary for medical instruments. Affordable, thin dividers are just the right thing for promotional and advertisement occasions. Thicker dividers are available for technical needs.

The standard colour is black; coloured and transparent inserts with textured or smooth surfaces are as well available.



Flocked plastic deep recessed inserts

To give special value to your products, present them on a velvet-textured surface with a flocked finish. Our black and coloured material which is always in stock guarantees an elegant result.



Compartment Divider Systems

Dividers come in handy when a large area needs to be compartmentalized.

Permanently mounted dividers

Permanently mounted dividers prove their worth when the compartments are constantly in use, especially in the professional field. They are indispensable for use as a standard tool case for larger products.



Variable Compartments

Variable compartments can be achieved with simply re-inserting the dividers into the pre-cut increments. This adjustable system ensures safe transport of the case's content. They could be laminated with foam for a safer transport.



Compartment Divider Systems

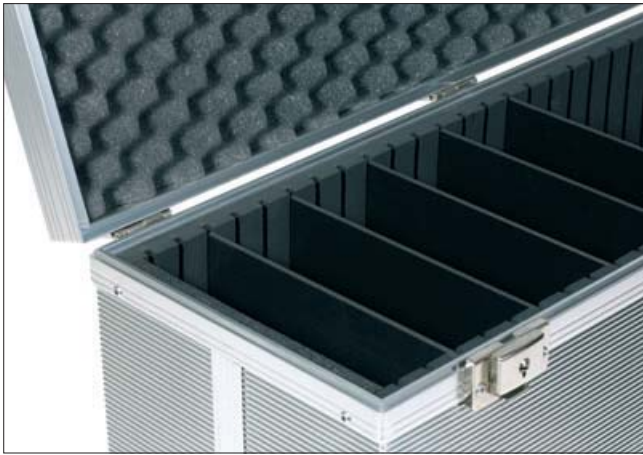

Notch-Insert System

Opposite case walls are lined with notch-insert rigid foam panels, fiber board or deep inserts. According to the needed size of compartments flexible dividers are easily slid into place.



Organisation Trays

Plastic assortment trays to achieve individual and perfect order for those small items in the case.

Four large coloured trays come as standard accessories. Customized colours, depending on the quantity, allow for limitless organization possibilities.

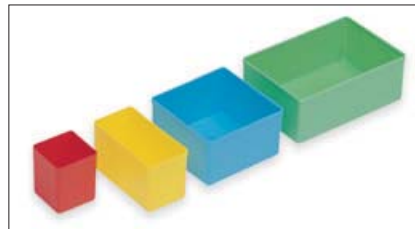

Specialised trays

Specialised trays are indispensable for categorizing, organizing and establishing a clear overview for presenting all those small items. There are no limits to the variations.



Panels and Mounting Boards

Panels and mounting boards for safe and protected separation of products in both upper and lower parts of the case. Documents and small items all have their place.

Lid Panel

The lid panel ensures that all contents remain neatly and safely in place during transport.



Organisation Panel

This panel acts not only to ensure that the contents remain in place but affords a diversity of possibilities for storage of documents and other items.



Tool Panel

Replaceable tool panel - able to be used in the lid as a storage and protection panel.

Either single or double-sided with elastic holding bands or pouches and pockets for tools and work material. Remove the panels and you have a universal case.



Panels and Mounting Boards



Cover Panel

A transparent cover panel serves as optimal protection of your products and gives a clear view of your presentation.

TROLLEY as mounting option

Removable roller systems contain 2 rollers and a multi-level retractable handle. In addition to the previous standard trolley with 50 mm large rollers, KKC offers now a comfort-alternative.

This contains even larger, gummed rollers with a diameter of 120 mm.

Thanks to the broadened wheel base the suitability for daily use will be more increased.



Comfort Trolley



Standard Trolley

Panels and Mounting Boards

Mounting and Front Boards

For measuring, electrical- or electronic technique the placement and mounting of instruments in case is essential. The case assembly and front board have been designed just for this purpose. The front boards are held in place by sliding nuts as well as angle extrusions with pop rivet nuts.



Electrical Cabling and Assembly

Electrical cabling and assembly can be expertly carried out according to given plans and parts lists due to complete VDE 0100 certified electrical cabling unit. Instruments and functional parts can be integrated in the printed front board of case.



Drawer Cabinets



Drawers are the professional solution for transporting and presenting small products, product parts or product groups.

A successful presentation is achieved by means of high quality drawer features such as foam inserts, deep recessed inserts or completely tailor-made solutions.



Drawer Cabinets on Rollers

As an added feature we can mount your specialised drawer cabinet on rollers. When size and weight of the drawer cabinet exceed carrying convenience, our roller system is mounted which enhances effortless mobility of the complete cabinet as, for example, a brochure display.

Drawer Cabinets

Removable Drawers

Not only can these drawers be extended for ideal viewing, but they are easily removed and replaced. Sophisticated and elegant features as well as custom coating bring out the quality of your product.



Drawers with Covers

For special requirements the drawers can be fitted with covers. This ensures a tight hold for content or serves as a display cover should there be a need for keeping certain items out of immediate view.

The drawer covers can be made of the same material as the drawer itself, if desired.



Foam Drawer

The foam drawers are advantageous due to the light-weight rigid foam material reinforced with a bottom panel. Ideal for small and light-weight products.

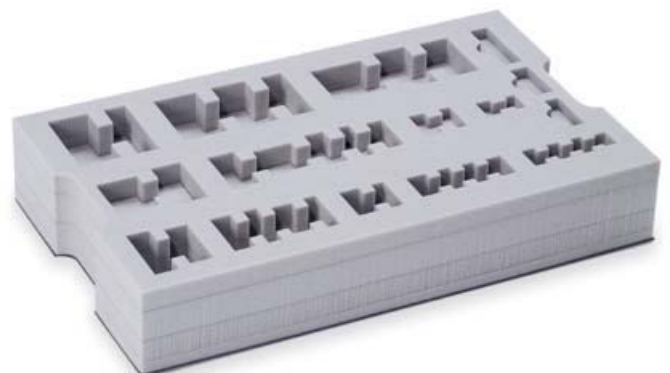

... for every case: Individualising with CI and Promotion.

Use the surface of your case or box to promote your company:

Depending on the choice of surface we offer a wide range of possibilities for your "message", your CI or your market presence to "catch the eye" of your potential customer.

Refine "your" case.

Show your colours; show your competence through identification to your firm. Promote and strengthen your new line of products.

Use your case to penetrate the market.

Labels / Transfer Labels



Screen-printing - Direct Printing



Laser Engraving (only on aluminium plate)



Embossing (only on aluminium plate)



Digital Print, multi-coloured



Labels / Dome Labels





KKC cases GmbH

Tailor-made Cases and Carrying Cases
Schröttinghauser Straße 20
32351 Stemwede-Levern

Tel. +49 (0)5745.92050
Fax +49 (0)5745.920529

info@kkc-cases.de
www.kkc-cases.de

