



Tailor-made solutions for

# Presentation & Promotion



**INDIVIDUAL** PRODUCTION

**MASS** PRODUCTION

**COMPONENTS** PRODUCTION

...for every case: Experience gained by 25 years of success.

Our solid growing team which reflects our sales figures, the ever increasing degree of awareness of the high profile name "KKC" as synonym for quality, willingness to perform and reliability all show that we have chosen the right path.

The individual sense of responsibility of our employees coupled with their long standing, strong bond with the company insure our continued high standards of quality.

In its area of product development KKC's range of high-quality presentation and transport packaging shows our absolute knowledge of and orientation towards the needs of the market.

KKC completes its standard program by offering individual custom solutions. In addition we enhance the products' unique features through perfect product presentation.

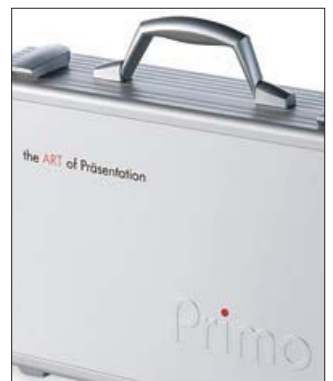

---

**...for every case: For every branch and every use.**

There is no branch of industry that KKC has not already supplied with its standard or custom-made cases and shipping cases.

Therefore be assured we will always find the solution for your needs. Whether it be industrial, advertising, in trade crafts, service providers, beverage companies, measurement and control technology, cosmetics, eye glasses, watchmakers, etc., etc., etc., ...



---

**...for every case: As a valued customer of KKC, be assured, you are in excellent company.**

The fact that others have chosen KKC says it all... it's that simple. We believe that the quality of our services is best reflected in the evaluation of customers.

Therefore our top priority is your satisfaction resulting in us becoming long-term business partners.

KKC's best reference is their long standing business relationships with prominent companies such as Robert Bosch, Bosch-Siemens-Household appliances, Buderus-Heating systems, Deutsche Telekom (German, Telecommunication), Christian Dior, Fujitsu-Siemens Computer, Gardena, HBM, Kraft-Jacobs, LVM-Insurance company, Philips AG, Trumpf engineering, Weinmann, WMF, Siemens and above all: you.



---

**...for every case: Our modern, well-structured production.**



Our high rate of efficiency is achieved due to production technology or our own design. Sophisticated machines standardise and duplicate procedures. Individual craftsmanship by hand is always used when highest accuracy and an expert eye is needed to result in that extra degree of quality and service.



---

**...for every case: Quality, security and perfection.**



Our cases, for the most part, are hand-made therefore optimal project along with the employees' motivation and identification with the company's philosophy and products are crucial factors.

KKC's employees' attitude is fixed on quality and as a result they assume personal responsibility for achieving and maintaining the company's high standard for production and quality control.

Why? Because we want your next order.



---

**...for every case: Delivery readiness and capabilities.**

KKC cases Ltd., in addition to its modern production facility, has the capability of responding rapidly to short notice orders. A solid equity base, a healthy understanding and insight regarding what is possible and essential, are prerequisites for optimal warehousing-, delivery- and logistical attitude of a company that wants to maintain a flexible response to the prevailing market situation. This puts us in the position of being able, when necessary, to act "ad hoc" in your best interest.



---

**...for every case: Innovative individual product development.**

This means that your KKC cases will be matched, modified or completely redesigned to be implemented exclusively to your products. Regardless of whether it required external embossing or screen printing, made in preferred materials or in your company's colours to enhance and represent your corporate identity. Regardless of whether a particular inner lining or a shock-resistant inner protection is required.

You can expect the right solution from us for all of your needs, regardless of the volume of the production series. Even complex electronic assembly is required (TÜV = Technical Inspection Certificate) safety seals presents no problem for us.



**...for every case: Small and large volume order for production series.**



KKC's production has been laid out for individuality and flexibility. Even the most extreme and unusual productions are possible. In order to meet these demands we have designed and perfected our own production equipment. We have designed assembly areas so ergonomically and flexible that they are suitable for producing in multiple dimensions. If no one has the answer, we are accomplished at finding solutions to challenges which as yet don't exist.



**...for every case: Simply challenge us.**



Today everyone is talking about motivated employees, customer-orientation, extreme flexibility, willingness to serve, and so on, and so on ...

But do you know what? We're already doing our utmost not only to win but also keep you as a satisfied customer. In this "case" you can be absolutely certain.

















# CONTENT

## References

3

## Product lines

---

PERFECT LINE	Aluminium Frame Cases	 	25	9
PRIMO	Aluminium Frame Cases and Etais (little cases)	 	100	17
PROFESSIONAL	Aluminium Frame cases	 	10	23
ECONOMY	Aluminium Frame Cases	 	300	35
LIBERO	Aluminium Etais (little cases) and Document cases	 	20	39
PLASTIC S	Injection-Moulded Plastic Cases			49
PLASTIC B	Blow-Moulded	 	900	57
COLOUR	The product line exactly corresponding to your imagination	 	100	61



## Features, Technique and Accessories

---

Technique	Mounting Forms, Explanation of all Pictograms	65
Mobility		66
Surfaces / Colours		68
Interior Design		70
		73

## Explanation

---

	Product line with available standard sizes.
 25	On orders of 25 or more individual cases, the choice of width, depth and height is arbitrary.
 100	On orders of 100 or more individual cases, the choice of width and septh is arbitrary. The height of the increment grid is arbitrary.

# PERFECT LINE

Aluminium Frame Cases





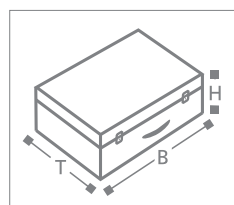

**PERFECT LINE Case**

- Rounded anodized aluminium frame extrusions
- Laminated surface in silver-grey Oslo No. 475 or black Oslo No. 421
- Lockable chrome snap locks
- Chromed Highline carrying handle
- Floating hinges, chrome plated
- Plastic corners with integrated foot studs
- Interior lining with washable synthetic surface

**Mobility and interior design are individually adaptable (see p. 65 and following pages).**

W/D/H (mm) Inside dimensions	Article No. Silver-grey	Article No. Black
345 x 255 x 70+47	130011.00	130011.01
400 x 300 x 70+47	130012.00	130012.01
440 x 320 x 78+47	130013.00	130013.01
500 x 400 x 110+50	130014.00	130014.01

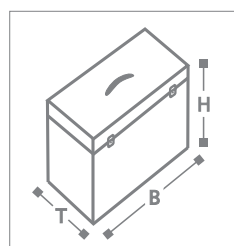

**PERFECT LINE Box**

- Rounded anodized aluminium frame extrusions
- Laminated surface in silver-grey Oslo No. 475 or black Oslo No. 421
- Lockable chrome snap locks
- Chromed Highline carrying handle
- Floating hinges, chrome plated
- Plastic foot studs with integrated foot studs
- Interior lining with washable synthetic surface

**Mobility and interior design are individually adaptable (see p. 65 and following pages).**

W/D/H (mm) Inside dimensions	Article No. Silver-grey	Article No. Black
325 x 140 x 170+50	130021.00	130021.01
390 x 200 x 200+60	130022.00	130022.01
450 x 200 x 260+60	130023.00	130023.01

## PERFECT LINE

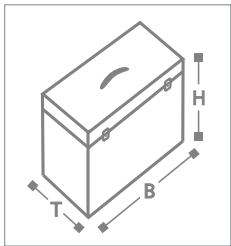

### PERFECT LINE Office-Roller

- Anodized aluminium frame extrusions
- Laminated surface in silver-grey Oslo No. 475
- Rollers with 150 mm diameter
- Retractable handle with swing mechanism
- Organiser tray in lid
- Compartment partitioning for hanging file system
- Variable compartments
- Removable plastic compartment for writing utensils

Flexible interior partitioning for all types of files and folders using a hanging file system. Variable partitioning using dividers, e.g. for notebooks.

Thanks to the retractable handle, mounted in exterior, the entire case capacity is usable. The lid could be opened without any difficulty even if the handle is drawn out.

	W/D/H (mm) Inside dimensions	Article No. Silver-grey
with rollers	405 x 220 x 300+47	130051.00

## PERFECT LINE

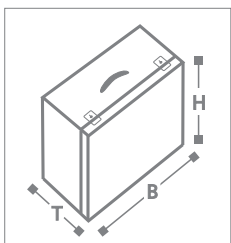

### PERFECT LINE Vendor-Roller

- Anodized aluminium frame extrusions
- Laminated surface in silver-grey Oslo No. 475
- Fitted with rollers, 150 mm diameter, and retractable handle
- Fitted with 3 drawers 40 mm high and 4 drawers 60 mm high
- Drawers are separately removable, empty
- Interior dimensions of drawers: 370 x 220 mm

Drawers can be individually fitted with rubber foam, partitioning system, small component bins and thermo-formed inserts.



	W/D/H (mm) Inside dimensions	Article No. Silver-grey
with rollers	414 x 307 x 410	130061.00

There are numerous individual options for the Perfect Line series due to a choice of multiple coloured surfaces and plastic corners or by mean of chrome coated finishing.

We offer diversity resulting from custom features and mobility through the use of our various roller systems.

Further information on pp. 65 - 84.



**K** Case, laminated surface silver-gey Oslo No. 475, interior light-grey rigid foam LD45, cut with water-jet.



**K** Case, laminated special colour, smooth, snap lock silver mat, Highline carrying handle, sticker on case surface.



**K** Case with laminated surface black Oslo No. 421. Top surface with single silk-screen printing. Plastic corners and connectors in black, automatic locks, silver mat, and Highline carrying handle mat.



**K** Case, aluminium smooth, anodized with single colour silk-screen printing. Combination locks, silver-grey, and Highline carrying handle, mat.



**K** Case, laminated surface yellow mandarin, extrusions black anodized. Coloured plastic corners, retaining eyelets for harness system. Interior with front panel and built in electrical components. The case can be used as a vendor's tray for promotional purposes.

**U** Uniport, laminated surface black mandarin, aluminium extrusions black anodized, plastic corners and all hardware in black. The upper lid has a transparent flap and pocket. In the lower part of the case is a die-cut foam insert, behind it there is a storage compartment. The front panel is fitted with a transparent pocket for displays.





**K** Case and box, aluminium, ribbed, anodized, chrome plated corners, chrome Highline carrying handle and chrome automatic locks.  
**B**



**K** Case, laminated surface silver-grey Oslo No. 475. Inside surface of lid with 3-colour silk-screen printing, in base is a die-cut rigid foam insert, made from LD29 in black, on top is a removable foam compartment made of rigid foam LD45 in light-grey.



**K** Case, laminated surface silver-grey Oslo No. 475, automatic locks, silver mat, Highline carrying handle, mat, finish sticker on case's surface.



**K** Case has a mounting plate in lid, the front plate in the body of the case is wired for electrical components. Case exterior has sockets for electrical and communication devices.

## PERFECT LINE Hardware solutions

### Locks

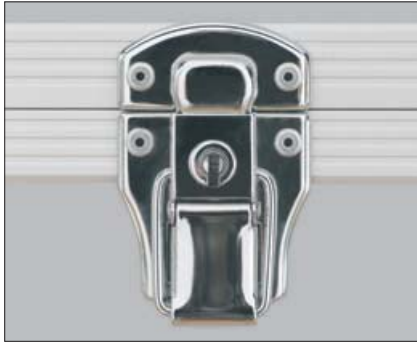

**Art.-No.620241:** Automatic lock, chrome, with key



**Art.-No.620203:** Automatic lock, silver mat, with key



**Art.-No.620220:** Snap lock, silver / silver mat, with key



**Art.-No. 620473:** Snap lock, black, with key

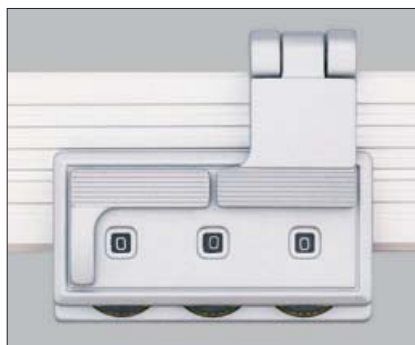

**Art.-No. 620074:** Combination lock, silver-grey

### Hinges

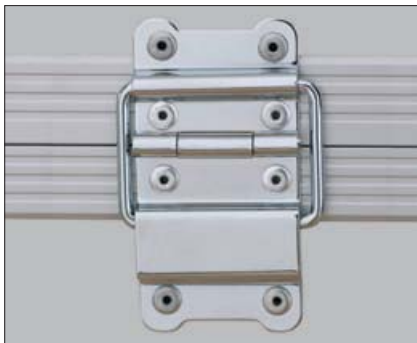

**Art.-No. 620244:** Floating hinge, chrome, 8-hole, opening 93°

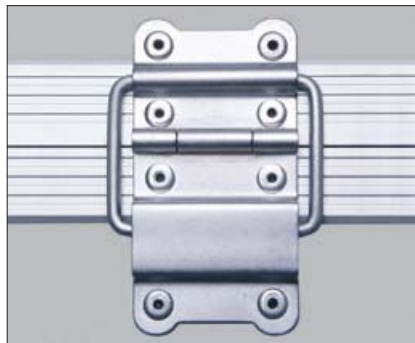

**Art.-No. 620208:** Floating hinge, silver mat, 8-hole, opening 93°



**Art.-No. 620098:** Floating hinge, black 8-hole, opening 93°



**Art.-No. 620262:** Detachable hinge, chrome, opening 180°



**Art.-No. 620152:** Pin hinge, chrome, detachable, opening 180°

All of the illustrated hardware is available for custom orders in the PERFECT LINE product line.

## PERFECT LINE Hardware solutions

### Handles



**Art.-No.** 620017: Handle Highline, silver mat



**Art.-No.** 620018: Handle Highline, chrome



**Art.-No.** 620286: Handle, black

### Corners

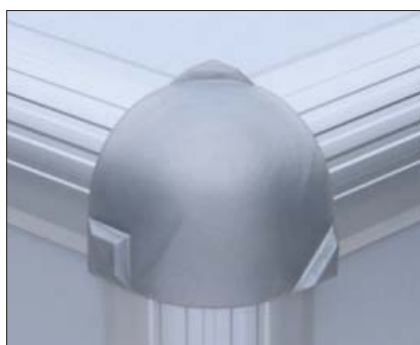

**Art.-No.** 620061: Corner, silver-grey



**Art.-No.** 620067: Corner, black

### Connectors



**Art.-No.** 620059 / 60: Connector, silver-grey



**Art.-No.** 620065 / 66: Connector, black

All of the illustrated hardware is available for custom orders in the PERFECT LINE product line.

# PRIMO

Aluminium Frame Cases





### PRIMO Case Aluminium smooth

- Anodized aluminium frame extrusions
- Surface anodized smooth aluminium
- Metal clip catches, chrome plated, without key
- Handle, ergonomically formed, silver-coloured
- Metal floating hinges, opening 93°, silver-coloured
- Interior empty

**Mobility and interior design are individually adaptable (see p. 65 and following pages).**

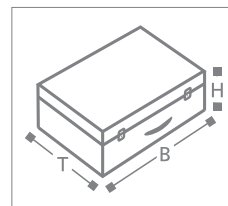

W/D/H (mm) Inside dimensions	Article No.
345 x 255 x 53+33	270030.05
415 x 315 x 63+33	270031.05
460 x 340 x 83+33	270032.05



### PRIMO Case Polystyrene light-grey

- Anodized aluminium frame extrusions
- Surface polystyrene light-grey
- Metal clip catches, chrome plated, without key
- Handle, ergonomically formed, silver-coloured
- Metal floating hinges, opening 93°, silver-coloured
- Interior empty

**Mobility and interior design are individually adaptable (see p. 65 and following pages).**

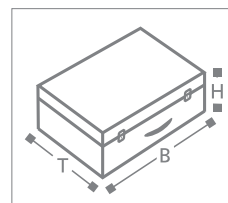

W/D/H (mm) Inside dimensions	Article No.
345 x 255 x 53+33	270010.05
415 x 315 x 63+33	270011.05
460 x 340 x 83+33	270012.05



### PRIMO Case Polystyrene black

- Anodized aluminium frame extrusions
- Surface polystyrene black
- Metal clip catches, chrome plated, without key
- Handle, ergonomically formed, silver coloured
- Metal floating hinges, opening 93°, silver-coloured
- Interior empty

**Mobility and interior design are individually adaptable (see p. 65 and following pages).**

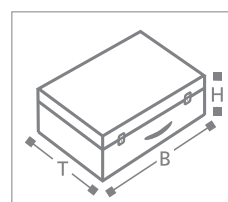

W/D/H (mm) Inside dimensions	Article No.
345 x 255 x 53+33	270020.05
415 x 315 x 63+33	270021.05
460 x 340 x 83+33	270022.05



# PRIMO

## PRIMO Etui (smaller case)

- Anodized aluminium frame extrusions
- Surface polystyrene black, silver-grey or aluminium plate, silver anodized
- Plastic clip catches
- Plastic hinges
- Interior empty

**Mobility and interior design are individually adaptable (see p. 65 and following pages).**

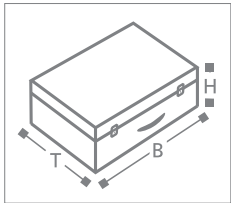

W/D/H (mm) Inside dimensions	Article No. light-grey	Article No. black	Article No. aluminium
180 x 130 x 33+33	270050.00	270050.01	270050.02
230 x 160 x 33+33	270051.00	270051.01	270051.02
270 x 200 x 33+33	270052.00	270052.01	270052.02
345 x 255 x 33+33	270053.00	270053.01	270053.02



## PRIMO Individual

PRIMO, the affordable solution for promotion and presentation cases as well as etuis. With top-grade design and finish, we produce these cases individually for you on orders of 100 cases or more. Standard dimensions with your corporate identity design are possible on short notice. Solutions for individual case dimensions are produced within 2 - 4 weeks.

### Affordable and attractive.

Shapely plastic catches could be used if it is required by tight budgets and if it is allowed by the case of application.



The following system's dimensions are available:

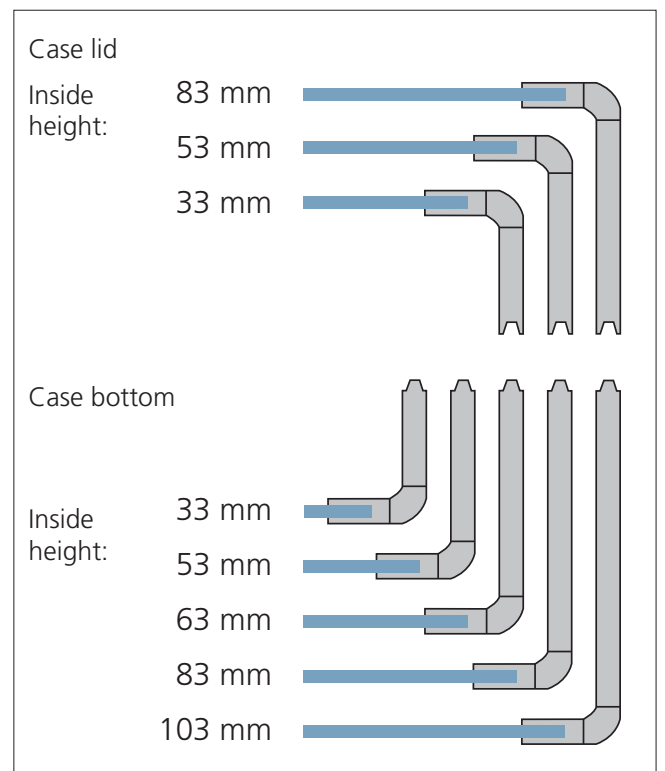



### Height increment grid

The PRIMO case system characterises itself by the use of aluminium sidewall profiles that allow for a variety of heights. These make up the increment grid that determines the size of the case.

The surface format of the case is arbitrary and is only limited by certain technical constraints.



### Lock

Aside from our standard locks we offer a variety of locks with special finish.

To ensure that your corporate identity is discreetly recognisable, your logo can be easily incorporated into the exterior design.



### Corporate Identity

Bring us your CI and your concept of how you want it to look; we'll make it happen: From screen printing and engraving on the case front to attractive signs and stickers.

When using our smooth aluminium plate surface the engraving possibilities are almost limitless. On orders of 100 or more the word „economical“ becomes even more interesting.

Another individual feature can be implemented by a coloured inlay within the handle base which corners are in standard colours of red and blue.

Eye-catching effects are attained when combining these colours with your logo.



## PRIMO Individual

### PRIMO Presentation Cases

A special solution for presenting a new collection. With this the observer shall find out the entire product range in visual sub-steps.

The guidelines of the customer were implemented by using printed flaps in lid and horizontal tableaus, fixed on telescopic slides supported by ball bearing.

Solid foam inserts - water-jet cut - mount the products in the case's bottom. The products in lid are mounted in a milled front plate.

The surface is made of laminate in special colour and completes the product presentation.



### PRIMO Transport Cases

Transport cases for a mother's milk pump with the entire assumption of hygiene and shelf life. This is a solution for specialist shops which rent these products.

The single components are mounted in two extremely durable and easy to clean plastic deep recessed inserts. The cut-outs were accurately verified with the individual incoming products. The instruction manual is printed on lid.



## PRIMO Individual



### PRIMO Presentation Cases

A perfect solution for labelling which catches the viewer's eyes.

The aluminium case emphasizes the value of the content. Surface, handle and the mat refined locks form an entire harmonious item for presentation and transportation.

On the left side the realisation was carried out with silk-screen printing or rather with an applied foil. All labelling are applied before production of the case.



### PRIMO Presentation of Cosmetics

Colour display, product presentation and PRIMO-cases are the perfect unit for supporting your sales representatives.

A 3-dimensional depth is milled in light-grey solid foam LD45. This attracts the focus directly of the cosmetics which are kept in another milled foam.

Product presentation is supported by the aluminium case in entire priority.

## PRIMO Hardware Variations



**Art.-No. 620135:** Clasp lock, chrome, with key



**Art.-No. 620004:** Clasp lock, chrome, without key



**Art.-No. 620049:** Clasp lock, silver mat, without key

# PROFESSIONAL

Aluminium Frame Cases





**PROFESSIONAL Cases**

- Anodized aluminium frame extrusions
- Laminated surface in silver-grey Oslo No. 475 or stone-grey mandarin No. 472
- Automatic locks, chrome plated
- Handle with chrome ring
- Floating hinges, chrome plated
- Plastic foot studs
- Steel corners, chrome plated
- Laminated with synthetic foil

**Mobility and interior design are individually adaptable (see p. 65 and following pages).**

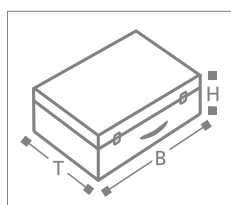

W/D/H (mm) Inside dimensions	Article No. Silver-grey	Article No. Stone-grey
345 x 255 x 85+40	71110.10	71110.20
385 x 235 x 65+40	71120.10	71120.20
420 x 310 x 90+40	71125.10	71125.20
460 x 340 x 115+40	71130.10	71130.20
520 x 390 x 125+50	71150.10	71150.20
595 x 395 x 135+50	71160.10	71160.20
650 x 410 x 180+50	71170.10	71170.20



**PROFESSIONAL Box**

- Anodized aluminium frame extrusions
- Laminated surface in silver-grey Oslo No. 475 or stone-grey mandarin No. 472
- Automatic locks, chrome plated
- Handle with chrome ring
- Floating hinges, chrome plated
- Plastic foot studs
- Steel corners, chrome plated
- Laminated with synthetic foil

**Mobility and interior design are individually adaptable (see p. 65 and following pages).**

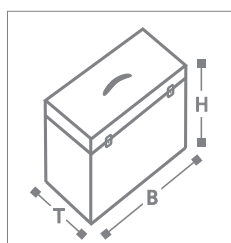

W/D/H (mm) Inside dimensions	Article No. Silver-grey	Article No. Stone-grey
325 x 130 x 180+40	75110.08	75110.20
405 x 210 x 200+50	75120.08	75120.20
450 x 260 x 275+50	75130.08	75130.20
486 x 275 x 340+50	75140.08	75140.20

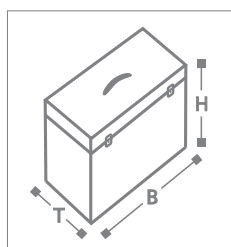

**PROFESSIONAL Office-Roller**

- Anodized aluminium frame extrusions
- Laminated surface in silver-grey Oslo No. 475
- Rollers, 150 mm diameter
- Retractable handle with swing mechanism
- Organisation tray in lid
- Partitioning compartment for hanging file system
- Adjustable compartments
- Removable plastic compartment for writing utensils

Adjustable interior compartments for use of all ring binders and / or hanging file systems. Compartments are fitted with adjustable dividers, e.g. for notebooks.

Thanks to the retractable handle, installed on the outside, the whole case capacity could be used. Even if the handle is pulled out, the lid could be opened without any problems.

	W/D/H (mm) Inside dimensions	Article No. Silver-grey
with rollers	402 x 215 x 300+50	71200.10

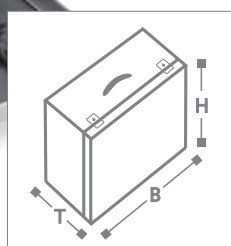

**PROFESSIONAL Vendor-Roller**

- Anodized aluminium frame extrusions
- Laminated surface in silver-grey Oslo No. 475
- Rollers, 150 mm diameter, and retractable handle
- Fitted with 3 drawers, each 40 mm high and 4 drawers, each 60 mm high
- Drawers separately removable, the inside base is padded with 5 mm foam
- Inside drawer dimensions 370 x 220 mm

Individual design of drawers with foam, dividing wall system, compartments for small items and deep recessed inserts.



	W/D/H (mm) Inside dimensions	Article No. Silver-grey
with rollers	410 x 290 x 400	71201.10

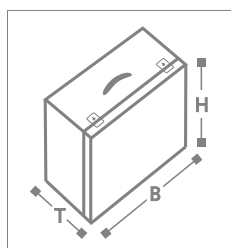

**PROFESSIONAL Flex-Vendor-Roller**

- Anodized aluminium frame extrusions
- Laminated surface in silver-grey Oslo No. 475
- Rollers and retractable handle
- Individually equipped with drawers. Could be equipped with 15 drawers at most.

**Drawers and foam are not included in the basic case and have to be ordered separately.**

- Drawers separately removable
- Inside drawer dimensions 378 x 250 mm

	W/D/H (mm) Inside dimensions	Article No. Silver-grey
with rollers	410 x 290 x 400	71301.10

Individual design of drawers with foam and deep recessed inserts.

**Drawers and standard foam inserts for Flex-Vendor-Roller**



**Foam Inserts**

Article No.	Type	Cut-outs	Cut-out dim. W x L x D in mm	Foam height mm
645329	1 HE	30 (writing utensils)		
645330	1 HE	12	80 x 66 x 18	20
645331	1 HE	4	80 x 66 x 18	20
		4	170 x 66 x 18	20
645332	2 HE	12	80 x 66 x 35	40
		4	80 x 66 x 35	40
645333	2 HE	4	170 x 66 x 35	40
		4	170 x 66 x 35	40
645334	3 HE	6	100 x 100 x 65	70
645335	3 HE	2	100 x 60 x 65	70
		4	100 x 100 x 65	70
		1	200 x 80 x 65	70

**Drawers**

Article No.	Type	Material Handle	Dimensions mm W x L	Height mm
645326	1 HE	Aluminium Knob	378 x 250	21
645327	2 HE	Aluminium Knob	378 x 250	48
645328	3 HE	Aluminium Knob	378 x 250	72



With this product line almost every solution is possible. Variety is achieved through individual design and the implementation of a wide choice of roller systems. Further information could be found on pages 65 to 84.



**K** Case, laminated surface in Anthracite 551 (in the background: silver-grey Oslo 475), in lid nap foam and on bottom a die-cut foam insert.



**U** Uniport, laminated surface in Black mandarin Document pouch and measuring instrument holders in lid. Case body lined with black powder-coated metal board, equipped with compartments for measuring devices. There are metal drawers for accessories. Holding straps for further measuring instruments are mounted inside the louvre.

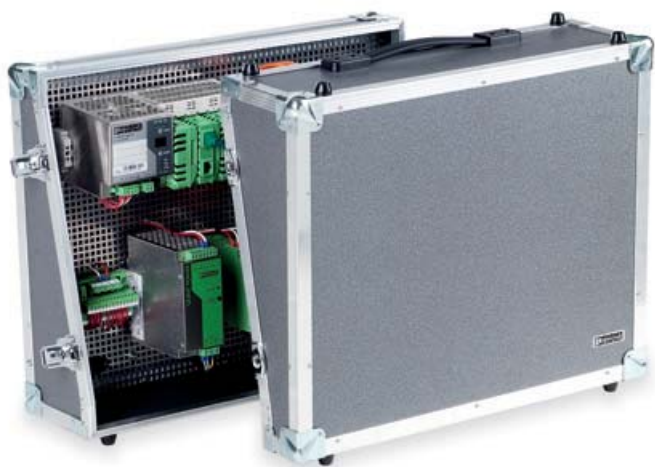

**X** X-Case, laminated surface in Anthracite 551 Case is made of two identical shells, cut in console form. Mounting plates are integrated in case interior to affix test circuits.



**X** X-Case, laminated surface in Anthracite 551 Attaché insert in lid for documents and tools, in bottom there is a mounting plate. Power connections are built into side wall as well as ergonomically designed front plate with various mounting possibilities for devices.



**S PROFESSIONAL Shopper PROFI**

The uses of the Shopper system are limitless. Shopper systems are manufactured with highest accuracy. This ensures that all shopper elements fit perfectly together.

This applies even to shopper elements which are bought some years later.

The standard system consists of several elements which could be combined individually. The standard interior decoration could be kept very flexible and from 10 same elements on, it could be equipped individually, e.g. with milled foam inserts.

The shopper system is perfect for your sales activities. There are, in the warehouse, car or van, various layers equipped with different materials ready for use. They will be individually packed for each case of application. This enables high flexibility and long-term benefits. Because of the comfortable 150 mm rollers the PROFI system is very mobile for nearly every area.



A pleasurable handling is due to the flexibility and rigidity of the retractable handle which is installed on the backside: Thanks to the installed skids you can get over stairs without having to carry the system. Any layers could be stacked thanks to the mounting on the lowest layer. The lid forms the top of the system. Together with the lid one or two layers could be transported without the base part.

Drawing with individual modification.



Lid H = 20 mm



Middle part H = 70 mm



Middle part H = 100 mm



Middle part H = 150 mm

 Base part H = 320 mm  
with office equipment

## PROFESSIONAL Shopper PROFI

Compile your Shopper PROFI individually. All parts are individually combinable. A complete system consists at least of base part, any middle part and lid.

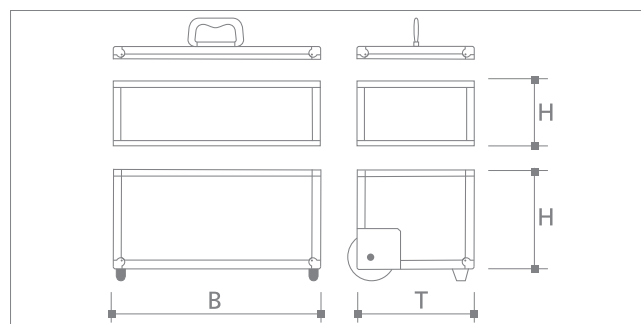

Type	W/D/H (mm) Inside dimensions	Article No.
Lid	450 x 300 x 20	71401.00
Middle part H70	450 x 300 x 70	71404.00
Middle part H100	450 x 300 x 100	71403.00
Middle part H150	450 x 300 x 150	71402.00
Base part H320	450 x 300 x 320	71400.00
Equipment Office for base part	450 x 300 x 320	71406.00

All middle and base parts are equipped with foam pads and each with 2 dividing walls which can be combined as required.

As an alternative you could choose the office equipment for hanging file system and dividing walls which can be combined as required.



Office - Equipment

If you order 10 or more shopper systems, we will manufacture the shopper system PROFI individually according to your specifications, even regarding size.



**S PROFESSIONAL Shopper BASIC**

In contrast to the shopper system PROFI, the shopper system BASIC has very compact dimensions. The decision for the one or the other system is only a result of the case of application.

The standard system BASIC consists of several individually combinable elements. The standard interior decoration could be kept very flexible and from 10 same elements on it could be kept individually, e.g. with milled foam inserts.

The shopper system BASIC is perfect for your sales activities. There are, in the warehouse, car or van, various layers equipped with different materials ready for use. They will be individually packed for each application. This enables high flexibility and long-term benefits. Because of the comfortable 80 mm rollers the system is very mobile for nearly every area.



A pleasurable handling is due to the flexibility and rigidity of the retractable handle which is installed on the backside. Thanks to the installed skids you can get over stairs without having to carry it. Any layers could be stacked thanks to the mounting on the lowest layer. The lid forms the top of the system. Together with the lid one or two layers could be transported without the base part.

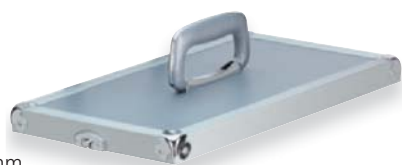

Lid H = 20 mm



Middle part H = 70 mm



Middle part H = 100 mm



Middle part H = 150 mm



Base part H = 300 mm  
with office equipment

## PROFESSIONAL Shopper BASIC

Compile your Shopper BASIC individually. All parts are individually combinable. A complete system consists at least of base part, any middle part and lid.

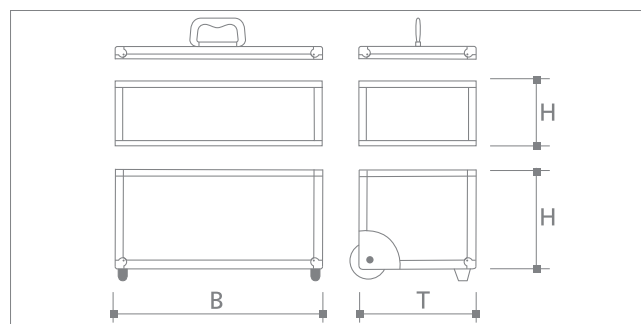

Type	W/D/H (mm) Inside dimensions	Article No.
Lid	380 x 220 x 20	71450.00
Middle part H70	380 x 220 x 70	71451.00
Middle part H100	380 x 220 x 100	71452.00
Middle part H150	380 x 220 x 150	71453.00
Base part H150	380 x 220 x 150	71454.00
Base part H300	380 x 220 x 300	71455.00
Equipment Office for base part H300	380 x 220 x 300	71456.00



Base part H = 150 mm

The padded base part H150 is equipped with 2 dividing walls which can be combined as required. The padded base part H300 offers with the arbitrary supplementary office equipment space for a hanging file system and folders in A4 format.

## PROFESSIONAL Hardware Solutions

### Locks

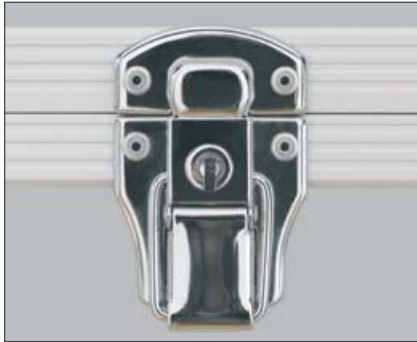

**Art.-No. 620241:** Automatic lock, chrome, with key



**Art.-No. 620203:** Automatic lock, silver mat, with key



**Art.-No. 620257:** Automatic lock, black, with key



**Art.-No. 620231:** Automatic lock, chrome, without key



**Art.-No. 620074:** Combination lock, silver-grey

### Hinges

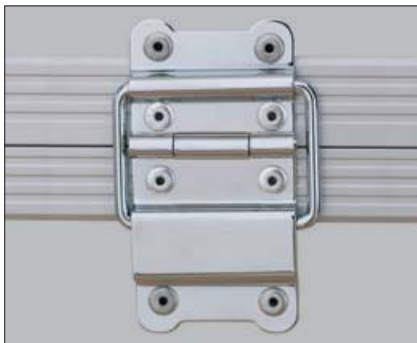

**Art.-No. 620244:** Floating hinge, chrome, 8-hole, opening 93°

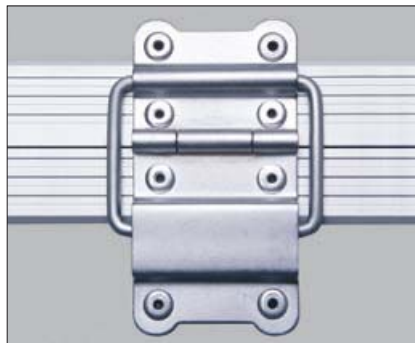

**Art.-No. 620208:** Floating hinge, silver mat, 8-hole, opening 93°



**Art.-No. 620098:** Floating hinge, black, 8-hole, opening 93°



**Art.-No. 620247:** Floating hinge, chrome, 8-hole, strengthened, opening 93°



**Art.-No. 620262:** Detachable hinge, chrome, opening 180°



**Art.-No. 620152:** Pin hinge, chrome, detachable, opening 180°

All pictured hinges in the PROFESSIONAL product line are available for custom-made productions.

## Handles



**Art.-No.** 620017: Handle Highline, glossy



**Art.-No.** 620018: Handle Highline, mat



**Art.-No.** 620298: Handle round, grey



**Art.-No.** 620246: Handle round, black

# ECONOMY

Aluminium Frame Cases





## ECONOMY



### ECONOMY Case

- Anodized aluminium extrusions in rounded design
- Aluminium plate, diamond structure surface
- U-locks, chrome plated, lockable
- Handle, light-grey
- Floating hinges
- Plastic foot studs
- Plastic corners, light-grey
- Black interior lining

**Interior design is individually adaptable (see p. 65 and following pages).**

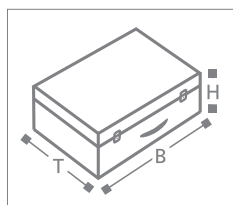

W/D/H (mm) Inside dimensions	Article No.
370 x 270 x 90+45	40310.04
420 x 300 x 90+45	40320.04
460 x 340 x 118+50	40400.04
500 x 400 x 100+50	40009.04
530 x 400 x 125+50	40330.04

## ECONOMY



### ECONOMY Box

- Aluminium frame extrusions in rounded design
- Aluminium plate, diamond structure surface
- U-locks, chrome plated, lockable
- Handle, light-grey
- Floating hinges
- Plastic foot studs
- Plastic corners, light-grey
- Black interior lining

**Interior design is individually adaptable (see p. 65 and following pages).**

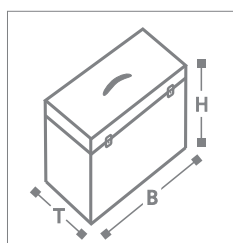

W/D/H (mm) Inside dimensions	Article No.
325 x 130 x 160+40	40501.04
400 x 140 x 195+40	40502.04

## ECONOMY



### ECONOMY Office-Case

- Anodized aluminium extrusions in rounded design
- Aluminium plate, diamond structure surface
- Combination locks, chrome plated
- Handle, light-grey
- Floating hinges
- Plastic foot studs, light-grey
- Light coloured interior lining
- Attaché insert in lid



W/D/H (mm)	Article No.
------------	-------------

440 x 305 x 65+40	40403.04
-------------------	----------

440 x 305 x 65+40	40403.04
-------------------	----------

440 x 305 x 65+40	40403.04
-------------------	----------

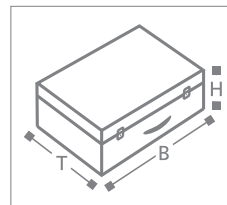

## ECONOMY



### ECONOMY Tec-Case

- Anodized aluminium extrusions in rounded design
- Aluminium plate, diamond structure surface
- Combination locks, chrome plated
- Strap hinges
- Handle
- Plastic foot studs
- Light coloured interior lining
- Writing utensils and business card holder in lid
- 2 removable compartments and 2 snap-fastening bags in base
- Trolley attachment adapter



W/D/H (mm)	Article No.
------------	-------------

443 x 198 x 314	40204.04
-----------------	----------

443 x 198 x 314	40204.04
-----------------	----------

443 x 198 x 314	40204.04
-----------------	----------

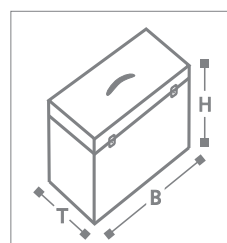



Tailor-made ECONOMY cases are an optimal solution for advertising campaigns and marketing purposes due to the extremely affordable price- and production ratio.

Due to production in Asia, time of delivery is approx. 3 months.

A large variety of solutions are available simply due to the selection of mounting forms and interior designs. Many cases in stock can be refined with features to meet your needs.



**B** Box, aluminium plate, diamond structure, silk-screen printing, grey



**K** Various cases with silk-screen printing and inside features.



**K** Case, surface aluminium plate, diamond structure. Light coloured interior lining. Lid, entire surface translucent. Acrylic glass with logo printed underneath, black frame. Lid interior with solar cell.



Silk-screen printing directly on case's surface (only possible during production).

**ECONOMY Hardware Variations**



Plastic handle, black



Plastic handle, light-grey



Plastic corner, light-grey, shock-resistant

# LIBERO

Aluminium Etuis (little cases)  
and Document Cases



**Surface identification number .xx**

- 01 Aluminium plate, ribbed
- 02 Aluminium plate, smooth
- 04 Silver-foil, brushed effect\*
- 08 Laminated surface silver-grey Oslo
- 09 Light-weight building board, black\*

**LIBERO Document Cases and Etuis**

- Rounded design
- Anodized aluminium frame extrusions
- Aluminium smooth or ribbed design, laminated surface silver-grey Oslo, silver-foil with brushed effect or light-weight building board, black
- Clip lock, black
- Hinges, black
- Protective plastic corners, black
- Interior lining with foil

W/D/H (mm) Inside dimensions	Article No. Height 25	Article No. Height 32	Article No. Height 40
A6 (145 x 240)	280001.xx	281001.xx	282001.xx
A5 (200 x 280)	280002.xx	281002.xx	282002.xx
A5+ (230 x 320)	280003.xx	281003.xx	282003.xx
A4 (255 x 355)	280004.xx	281004.xx	282004.xx
A4+ (290 x 395)	280005.xx	281005.xx	282005.xx
A3 (360 x 520)	280007.xx	281007.xx	282007.xx

\* not available in height 32

**Surface identification number .xx**

- 01 Aluminium plate, ribbed
- 02 Aluminium plate, smooth
- 04 Silver-foil, brushed effect\*
- 08 Laminated surface silver-grey Oslo
- 09 Light-weight building board, black\*

**LIBERO Document Cases and Etuis**

- Rounded design
- Anodized aluminium frame extrusions
- Aluminium smooth or ribbed design, laminated surface silver-grey Oslo, silver-foil with brushed effect or light-weight building board, black
- Clip lock, silver-grey
- Hinges, silver-grey
- Protective plastic corners, silver-grey
- Interior lining with foil

W/D/H (mm) Inside dimensions	Article No. Height 25	Article No. Height 32	Article No. Height 40
A6 (145 x 240)	283001.xx	284001.xx	285001.xx
A5 (200 x 280)	283002.xx	284002.xx	285002.xx
A5+ (230 x 320)	283003.xx	284003.xx	285003.xx
A4 (255 x 355)	283004.xx	284004.xx	285004.xx
A4+ (290 x 395)	283005.xx	284005.xx	285005.xx
A3 (360 x 520)	283007.xx	284007.xx	285007.xx

\* not available in height 32

## LIBERO Individual



20

### Standardised Flexibility

5 standard surfaces are available:

- Light-weight building board (LBL), black
- Aluminium ribbed
- Silver-foil, brushed effect
- Laminate silver-grey Oslo No. 475
- Aluminium smooth



### Individual Corners

Libero document cases are available with black or silver corners. With orders exceeding 500 cases, silver-finished corners are available. Individualised corners in Pantone colours are available with orders of 1,000 or more cases.

### Versatile Lock Solutions

Optionally we are supplying Libero document cases with following lock solutions

- Clip lock, silver-grey
- Clip lock, black
- Draw clamp, chrome plated
- Draw clamp, black



## LIBERO Individual



20

### Individuality through laser engraving, embossing or silk-screen printing

Individualised design with orders of 50 document cases or more at affordable prices:

- One and multi-colour silk-screen printing
- Laser engraving on smooth aluminium plate
- Embossing as high quality labelling



### Room for your ideas



#### LIBERO 25

Content height 25 mm. Horizontal and vertical adjustable elastic bands to prevent movement of contents.

#### LIBERO 32

Content height 32 mm. The same outside height as LIBERO 25 but with significantly greater interior height. Outer surface optional in aluminium smooth and ribbed, as well as various laminates. Permanently mounted elastic bands which adjust to any position.

#### LIBERO 40

Content height 40 mm. Permanently mounted elastic bands which adjust to any position.

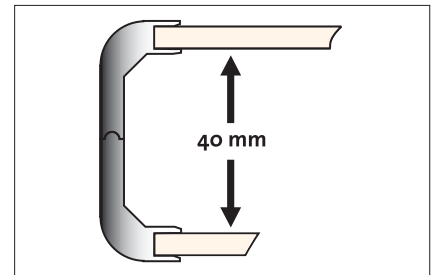
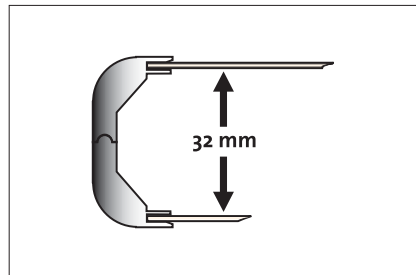
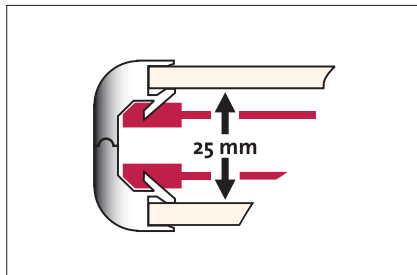

#### Conference I

Format: A4 (255 x 355 mm)

Height: 25/32/40 mm

Lock: Clip lock

Interior left: Elastic bands horizontal

Interior right: Clipboard holder, metal pen holder

## LIBERO Document Case-Samples Individual

 20

### Case III

Format: Your choice  
Height: 40 mm  
Lock: Draw clamp  
Interior left: Foam insert with presentation compartment for 5 watches  
Interior right: Foam insert with presentation compartment for 3 watches, various tools and cleaning materials



## LIBERO Document Case-Samples Individual

 20

### Conference Exclusiv I

Format: A4 (255 x 355 mm)  
Height: 40 mm  
Lock: Clip lock  
Interior left: Velour design in brown with leather application, document pouch, business card and double pen holder, pocket  
Interior right: Velour design in brown, pocket for writing pad



Height	Surface	Hardware	Article No.
40 mm	Alu smooth	silver-grey	285008.02
40 mm	Alu ribbed	silver-grey	285008.01





**Conference Exclusiv II**

Format: A4 (255 x 355 mm)  
 Height: 32 / 40 mm, hardware silver-grey  
 Lock: Clip lock  
 Interior left: Velour design in grey with leather application in black, business card- and double pen holder  
 Interior right: Velour design in grey with leather application in black, pocket for **writing pad**

Height	Surface	Hardware	Article No.
32 mm	Alu smooth	silver-grey	284008.02
32 mm	Alu ribbed	silver-grey	284008.01
40 mm	Alu smooth	silver-grey	285008.05
40 mm	Alu ribbed	silver-grey	285008.04



**Conference Exclusiv III**

Format: A4 (255 x 355 mm)  
 Height: 40 mm, hardware silver-grey  
 Lock: Clip lock  
 Interior left: Velour design in brown with leather application in black, document pouch, business card- and double pen holder, pocket  
 Interior right: Velour design in brown with ring binder mechanism for A4

Height	Surface	Hardware	Article No.
40 mm	Alu smooth	silver-grey	285008.09
40 mm	Alu ribbed	silver-grey	285008.08



**Conference Exclusiv IV**

Format: A4 (255 x 355 mm)  
 Height: 40 mm, hardware silver-grey  
 Lock: Clip lock  
 Interior left: Velour design in grey with leather application in black, document pouch, business card- and double pen holder, pocket  
 Interior right: Velour design in grey with leather application in black, pocket for writing pad

Height	Surface	Hardware	Article No.
40 mm	Alu smooth	silver-grey	285008.11
40 mm	Alu ribbed	silver-grey	285008.13

## LIBERO Document Case-Samples Individual



20

### Promotion XI

Format: A5+ (230 x 320 mm)  
Height: 40 mm  
Lock: Clip lock  
Interior left: Blue and grey foam, contour cut and printed  
Inhalt rechts: Blue and grey foam, contour cut and printed, acrylic glass lid, printed



### Promotion XII

Format: A5+ (230 x 320 mm)  
Height: 25 mm  
Lock: Draw clamp  
Interior left: Lining with foil  
Interior right: Deep recessed insert for eye glasses



## LIBERO Document Case-Samples Individual



20

### Case I

Format: A4 (255 x 355 mm)  
Height: 40 mm  
Lock: Clip lock  
Interior left: Display with protective foil  
Interior right: Milled rigid foam insert, black



### Case II

Format: Your choice  
Height: 25/32/40 mm  
Lock: Draw clamp  
Interior left: Empty  
Interior right: Deep recessed insert, flocked and printed



45



**FLIPad®**

Flipad is a professional folder or rather case for your sales personnel. All in all it is a writing pad, flipchart, sales folder, dust jacket and presentation stand for tablet computers like Apple iPad1, iPad2 and iPad3. Please refer to [www.flipad.de](http://www.flipad.de) for all current computer models.

Description	Article No.
FLIPad® Silver/Silver, with writing pad	290467
FLIPad® Silver/Carbon fibre optic, with writing pad	290468
FLIPad® Silver/Silver, without writing pad	290465
FLIPad® Silver/Carbon fibre optic, without writing pad	290466
Handle	620212

Watch the film to get an impression of the function.



Further information at [www.flipad.de](http://www.flipad.de)



**Flipchart I**

Format: A4 horizontal / A3 horizontal  
 Height: 40 mm  
 Lock: Draw clamp  
 Interior left: Positioning board with ring binder mechanism for hole punch 80-80-80  
 Interior right: empty

Format	Surface	Article No.
A4 Horizontal	Alu smooth	285100.02
A4 Horizontal	Alu ribbed design	285100.01
A3 Horizontal	Alu smooth	285101.02
A3 Horizontal	Alu ribbed design	285101.01

## LIBERO Aluminium Protection Case „alu2GO“

### alu2GO

A timeless classical design made of noble aluminium:  
The new PROTECTION-Case alu2GO.

Your notebook, such as MacBook, or your tablet computer, such as iPad, will be protected by top quality rigid foam. With this your appliance could withstand a fall from your desk or from your hands without any trouble. It will rest intact without any scratches or broken / disrupted display.

The alu2GO-case is the professional dust jacket for your appliances, made of aluminium.



Format:	Various
Height:	32 mm
Lock:	Clip lock
Interior left:	Foam pad, grey
Interior right:	Foam pad, grey
Special feature:	An individual engraving is included in the shipment.



alu2GO for	Dimensions (mm)	Article No.
iPad2 / iPad3	272 x 216 x 32	290519
MacBook Air 11"	340 x 232 x 32	290520
MacBook Air 13"	365 x 267 x 32	290521
MacBook Pro 13"	365 x 267 x 32	290522
MacBook Pro 15"	404 x 290 x 32	290523

Your appliance is not mentioned?  
Please refer to our website to get information on the availability: [www.alu2GO.de](http://www.alu2GO.de)



# PLASTIC S

Injection-Moulded Plastic Cases





## Licase Black / Blue / Grey

- Injection-moulded case of impact resistant polypropylene
- Type 2.10 and 2.8 made of polystyrene
- Case halves identical
- Flap locks
- Integrated handle
- Integrally moulded hinges
- Integrated foot studs
- Finely textured surface
- but type 2.12, 2.9 and 2.5 smooth

**Interior design is individually adaptable (see p. 73 and following pages).**



Colour combination of standard cases

Type	W/D/H (mm) Inside dimensions	Case: Black Lock: Red	Case: Grey Lock: Blue	Case: Blue Lock: Red	Quantity PU*
Licase 2.12	120 x 80 x 24	420312.00	420312.01	420312.02	25
Licase 2.9	153 x 107 x 30	420309.00	420309.01	420309.02	25
Licase 2.5	170 x 130 x 37	420300.00	420300.01	420300.02	33
Licase 2.1	240 x 170 x 42	420301.00	420301.01	420301.02	10
Licase 2.4	270 x 185 x 76	420302.00	420302.01	420302.02	13
Licase 2.2	270 x 185 x 93	420303.00	420303.01	420303.02	10
Licase 2.6	335 x 240 x 71	420304.00	420304.01	420304.02	10
Licase 2.0	340 x 250 x 53	420305.00	420305.01	420305.02	13
Licase 2.7	365 x 245 x 105	420306.00	420306.01	420306.02	5
Licase 2.11	375 x 265 x 80	420311.00	420311.01	420311.02	8
Licase 2.3	410 x 272 x 113	420307.00	420307.01	420307.02	5
Licase 2.10	422 x 299 x 123	420310.00	420310.01	420310.02	5
Licase 2.8	445 x 328 x 144	420308.00	420308.01	420308.02	5

\* Please note: Plastic cases are only sold in complete packaging units.



## Licase Translucent

- Injection-moulded cases of impact resistant polypropylene
- Case halves identical, colour: translucent
- Flap locks blue-coloured

**Interior design is individually adaptable (see p. 73 and following pages).**

Type	W/D/H (mm) Inside dimensions	Case: Transparent Lock: Blue	Quantity PU*
Licase 2.12	120 x 80 x 24	420312.16	25
Licase 2.9	153 x 107 x 30	420309.16	25
Licase 2.5	170 x 130 x 37	420300.16	33
Licase 2.1	240 x 170 x 42	420301.16	10
Licase 2.4	270 x 185 x 76	420302.16	13
Licase 2.2	270 x 185 x 93	420303.16	10
Licase 2.6	335 x 240 x 71	420304.16	10
Licase 2.0	340 x 250 x 53	420305.16	13
Licase 2.7	365 x 245 x 105	420306.16	5
Licase 2.11	375 x 265 x 80	420311.16	8

## PLASTIC S



### Licase Blue-Translucent

- Injection-moulded cases of impact resistant polypropylene
- Cases halves identical, colour: blue and translucent
- Flap locks, colour: blue

**Interior design is individually adaptable (see p. 73 and following pages).**



Type	W/D/H (mm) Inside dimensions	Case: Blue/Translucent Lock: Blue	Quantity PU*
Licase 2.12	120 x 80 x 24	420312.15	25
Licase 2.9	153 x 107 x 30	420309.15	25
Licase 2.5	170 x 130 x 37	420300.15	33
Licase 2.1	240 x 170 x 42	420301.15	10
Licase 2.4	270 x 185 x 76	420302.15	13
Licase 2.2	270 x 185 x 93	420303.15	10
Licase 2.6	335 x 240 x 71	420304.15	10
Licase 2.0	340 x 250 x 53	420305.15	13
Licase 2.7	365 x 245 x 105	420306.15	5
Licase 2.11	375 x 265 x 80	420311.15	8

\* Please note: Plastic cases are only sold in complete packaging units.

### Licase White

- Injection-moulded cases of impact resistant polypropylene
- Cases halves identical, colour: white
- Flap locks, colour: grey
- Flap locks are also available in different colours without having to pay an additional charge, see p. 52

**Interior design is individually adaptable (see p. 73 and following pages).**



Type	W/D/H (mm) Inside dimensions	Case: White Lock: Grey	Quantity PU*
Licase 2.12	120 x 80 x 24	420312.13	25
Licase 2.9	153 x 107 x 30	420309.13	25
Licase 2.5	170 x 130 x 37	420300.13	33
Licase 2.1	240 x 170 x 42	420301.13	10
Licase 2.4	270 x 185 x 76	420302.13	13
Licase 2.2	270 x 185 x 93	420303.13	10
Licase 2.6	335 x 240 x 71	420304.13	10
Licase 2.0	340 x 250 x 53	420305.13	13
Licase 2.7	365 x 245 x 105	420306.13	5
Licase 2.11	375 x 265 x 80	420311.13	8





**Licase Transparent**

- Injection-moulded cases of impact resistant polystyrene
- Cases halves identical, colour: transparent
- Flap locks black-coloured
- Flap locks are also available in different colours with no additional charge, see p. 52

**Interior design is individually adaptable (see p. 73 and following pages).**

Type	W/D/H (mm) Inside dimensions	Case: Transparent Lock: Black	Quantity PU*
Licase 2.12	120 x 80 x 24	420312.17	25
Licase 2.9	153 x 107 x 30	420309.17	25
Licase 2.5	170 x 130 x 37	420300.17	33
Licase 2.4	270 x 185 x 76	420302.17	13
Licase 2.2	270 x 185 x 93	420303.17	10
Licase 2.7	365 x 245 x 105	420306.17	5

\* Please note: Plastic cases are only sold in complete packaging units.

**PLASTIC S Licase**



**Optional Accessories**

The real eye-catcher: Combine your case with flap locks in a suitable colour regarding your company's logo.

When ordering up to 500 cases, we will supply flap locks in colours which vary from the standard colours as stated below for a minor additional charge.

For Licase White and Licase Transparent this is possible without any additional charge.

**Spectrum of flap lock colours:**

Colour:	2	4	5	6	8	9	10	17	19	21	22	23
	White	Yellow	Orange	Red	Blue	Grey	Black	Mint Green	Purple	Grass-Green	Moss-Green	Bordeaux



Nap foam interior decoration  
Deliverable for all cases on demand



Dividing / Lid boards  
Deliverable for many sizes



Compartment Organisation  
Different split-ups available



# PLASTIC S



## Picase XL

- Strong and sturdy polypropylene construction
- Integrated handle
- Flap locks, black-coloured
- Integrally moulded hinges, solid
- Integrated foot studs
- Surface with (fine) structure
- Type 48... and Type 57... are strengthened with honeycomb structure



Interior design is individually adaptable (see p. 73 and following pages).

Type Black	W/D/H (mm) Inside dimensions	Case colour: Black RAL 90005	Case colour: Anthracite RAL 7024	Case colour: Navy Blue RAL5002	Case colour: Yellow RAL 1021	Case colour: Blue RAL 5005	Case colour: Green RAL 6029	Case colour: Red RAL 3020
XL 27070	270 x 201 x 35 + 35	420700.00	420700.12	420700.03	420700.06	420700.01	420700.05	420700.14
XL 40100	400 x 320 x 50 + 50	420710.00	420710.12	420710.03	420710.06	420710.01	420710.05	420710.14
XL 40125	400 x 320 x 75 + 50	420711.00	420711.12	420711.03	420711.06	420711.01	420711.05	420711.14
XL 40150	400 x 320 x 75 + 75	420712.00	420712.12	420712.03	420712.06	420712.01	420712.05	420712.14
XL 40151	400 x 320 x 100 + 50	420713.00	420713.12	420713.03	420713.06	420713.01	420713.05	420713.14
XL 40175	400 x 320 x 100 + 75	420714.00	420714.12	420714.03	420714.06	420714.01	420714.05	420714.14
XL 40200	400 x 320 x 100 + 100	420715.00	420715.12	420715.03	420715.06	420715.01	420715.05	420715.14
XL 48150	480 x 376 x 75 + 75	420720.00	420720.12	420720.03				
XL 48175	480 x 376 x 100 + 75	420721.00	420721.12	420721.03				
XL 48200	480 x 376 x 100 + 100	420722.00	420722.12	420722.03				
XL 48225	480 x 376 x 150 + 75	420723.00	420723.12	420723.03				
XL 48250	480 x 376 x 150 + 100	420724.00	420724.12	420724.03				
XL 48300	480 x 376 x 150 + 150	420725.00	420725.12	420725.03				
XL 57150	570 x 445 x 75 + 75	420730.00	420730.12	420730.03				
XL 57175	570 x 445 x 100 + 75	420731.00	420731.12	420731.03				
XL 57200	570 x 445 x 100 + 100	420732.00	420732.12	420732.03				
XL 57225	570 x 445 x 150 + 75	420733.00	420733.12	420733.03				
XL 57250	570 x 445 x 150 + 100	420734.00	420734.12	420734.03				
XL 57300	570 x 445 x 150 + 100	420735.00	420735.12	420735.03				

All cases 27... and 40... are on demand available in white and translucent when the order exceeds a quantity of 25 cases.

## Variety of colours

As standard the case is black coloured. When ordering more than 50 cases, 6 further colours are available without any additional charge. With this individual solutions are feasible. Furthermore we offer individual foam inserts.



The honeycomb structure makes Picase XL cases extremely sturdy (except XL 27070).



## Mobility

For a comfortable transport we offer a special trolley with adapter plate for safe standing.



## Picase N

- Cases made of impact resistant polypropylene
- Case halves identical
- Flap locks, selectable according to standard colours
- Integrated handle
- Hinges with steel core
- Lid positioner 90°, removable
- Integrated foot studs
- Finely textured surface

**Interior design is individually adaptable.**

## New colours

All types of Picase N are also available in following colours: translucent (.08), red (.14) and anthracite (.12) when ordering 1,000 cases or more.



Lid positioner



Type	W/D/H (mm) Inside dimensions	Article No. Black	Article No. Blue	Article No. Grey	Article No. Navy-Blue	Article No. Red	Article No. Green	Article No. Yellow	Article No. White	Quantity PU**
Swing	165 x 120 x 30	420217.00	420217.01	420217.02	420217.03	420217.04	420217.05	420217.06	420217.07	115
Drive	195 x 130 x 40	420216.00	420216.01	420216.02	420216.03	420216.04	420216.05	420216.06	420216.07	70
Dart	230 x 165 x 50	420215.00	420215.01	420215.02	420215.03	420215.04	420215.05	420215.06	420215.07	40
Jump	265 x 180 x 60	420214.00	420214.01	420214.02	420214.03	420214.04	420214.05	420214.06	420214.07	32
Pace	320 x 230 x 70	420213.00	420213.01	420213.02	420213.03	420213.04	420213.05	420213.06	420213.07	12
Sprint	380 x 275 x 80	420212.00	420212.01	420212.02	420212.03	420212.04	420212.05	420212.06	420212.07	10
Pounce	450 x 300 x 100	420211.00	420211.01	420211.02	420211.03	420211.04	420211.05	420211.06	420211.07	10
Glide	530 x 340 x 120	420210.00	420210.01	420210.02	420210.03	420210.04	420210.05	420210.06	420210.07	4

\*\* Please note: Plastic cases are only sold in complete packaging units.

## Foam interior design

Just the individual interior design - in this case milled foam insert - protects the products and presents them effectively. We produce such foam inserts and equip the cases with these inserts, if required.



## Silk-screen printing on Picase N



## PLASTIC S Individual



### Image printing for Picase Types

Image printing on the cases is possible by using in-mould labelling. The printing motif will be involved in the production process and will melt together with the case. Life period of this branding is even longer than all silk-screen printing methods.



There are nearly no limits for designing the motif. Recognition value of your products increases enormously. This type of printing is available for orders exceeding 100 cases.



### Silk-screen printing for Licase and Picase

Using surfaces of Plastic S as advertising space for your own company:  
Presentation of your company's CI by using silk-screen printing, labels or rather etiquettes.



## PLASTIC S Interior Decoration



**K** Soft foam insert, cut to your needed form, Nap foam in lid



**K** Foam insert, die-cut, Nap foam in lid



**K** Deep recessed insert of black plastic in bottom and lower section



**K** Foam insert, milled, cut-outs with different heights. Nap foam in lid, glued in, as counter bearings.



**K** Foam insert, cut with water-jet, cut-outs partly with different heights. Upper and lower parts are held securely in place by a separately fitted panel which is placed in before closing the case.



**K** Deep recessed compartment tray, standard feature for Licase models

# PLASTIC B

Blow-Moulded Plastic Cases





**PLASTIC B Arcas**

- Double-walled blown half-shells
- Colour: black
- Sturdy interlocking hinges
- Flap locks with hinge, black
- Integrated handle
- Integrated foot studs
- Textured surface
- Inside empty

**Interior design individually adaptable (see p. 73 and following pages).**

Type	W/D/H (mm) Inside dimensions	Article No. Black	Quantity PU*
310	473 x 350 x 100	410021	6
315	525 x 370 x 150	410020	4
421	650 x 415 x 210	410022	2

\* Please note: Plastic cases are only sold in complete packaging units.



**PLASTIC B Individual**

**Special cases**

Arcas Type 315 and 421 in special colour red. Thick ribbed design makes cases easy to stack.

**Clip locks**

Clip locks with sturdy hinges are available in standard colours on orders of 50 cases or more.



Clip lock, open



Clip lock, turquoise



Clip lock, red



Clip lock, blue



Clip lock, yellow



Clip lock, grey



**K** Arcas Type 310  
Case with die-cut rigid foam insert in bottom  
(PU) soft foam in lid



**K** Arcas Type 315  
Case in special colour red, with milled rigid foam  
in bottom and lid



**K** Arcas Type 315  
Case with water-jet cut rigid foam in bottom  
(PU) nap foam in lid



**K** Arcas Type 310  
Standard case with customised interior form.  
The costs of the specially designed tool which is  
necessary to produce the insert, are quickly  
amortised with orders of 1,000 or more cases.



**K** Arcas Special Case  
Customised exterior and interior design in blue.  
The costs of the two specially designed tools which  
are necessary to produce the insert, are quickly  
amortised with orders of 1,00 or more cases or with  
the intention of follow-up orders.

# COLOUR

The product line exactly to your requirements







**COLOUR The individual product line**

Your idea - we'll make it possible.  
 This means concretely:  
 We'll offer us to you to be the developer of your presentation solution.  
 Be it that we develop a new product line or that we create new handles and locks or individual surfaces with RAL colour indication.  
 Even case measurements could be individually adjusted thanks to the CNC controlling of our modern sheet metal forming machines.

We are able - for appropriate ordered quantities - to deliver the complete individual case at a remarkable price- and performance ratio.

Present us your idea, preferably already during the development stage. Use our know-how for a cost-effective individual or components production.

We'll present you on the following pages examples of our Colour product line which are totally individual regarding surface, locks, handles and interior decoration.

**Formats of the pictured product line**

- Base = Height 75 mm
- Lid = Height 25 mm
- Width = Individually selectable from 200 up to 500 mm
- Depth = Individually selectable from 200 up to 500 mm

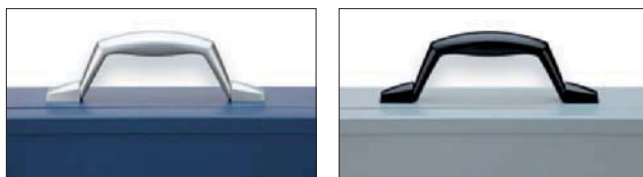

**Individual colour of handle**

As standard you will get a silver coated handle with a different coloured hand pad.  
 For orders exceeding 500 cases you could choose an individual RAL colour for the handle.



## COLOUR

### Colours

This special product line is basically offered in your desired colour. The very sturdy surface is produced with an individual powder coating. The case is completely coated in your desired colour and could be therefore implemented ideally in your advertising or promotion campaign.



### The special lock

The lock solution is extraordinary and unique. We'll use a press button which could also be in the same colour as the case.



### The peak of individuality

is achieved if customer's products are integrated in the case solution.

### Custom-made interior decoration

You will get a complete solution with interior decoration which could be milled or lasered in the foam.



### Guaranty all around

Our experience of 25 years gained in the sector of creation of customer solutions and case production guarantees you a solution-oriented product for your intended purpose.



# FEATURES

Mounting forms, technique and accessories



## Structural Shapes



## Structural Shapes

Mechanical drawings or schematic diagrams are one thing. In conjunction with the reality, technique is sometimes easier to explain. For a better understanding of the structural shapes, we have faced some real examples.

## Structural Shapes

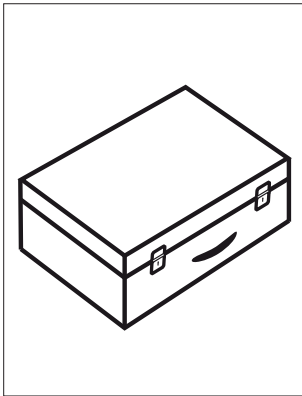

### **K** Case

This all-purpose case has a short production time. Individual solutions are possible on short notice.

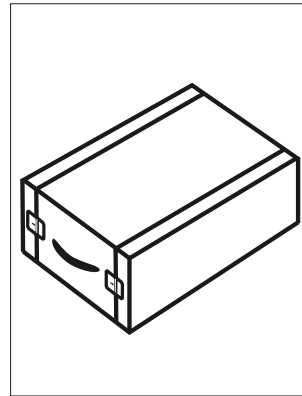

### **R** Rack

The rack is the professional solution for transportation of measuring devices, either padded on all sides with foam or with an integrated front panel.

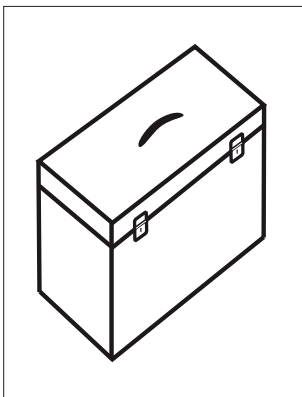

### **B** Box

The box is ideal for transporting high or tall products, with fewer bottom area and necessary height.

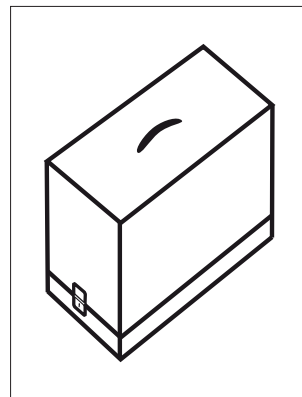

### **H** Hood

The hood is ideal for presentation contents. Completely protected from all sides, but totally accessible once removed. Especially functional for heavy equipment.

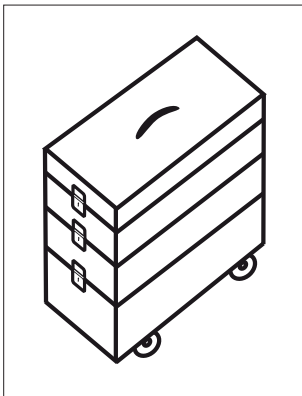

### **S** Shopper

The shopper has optimal flexibility for presentation / vendor uses with its foam inserts which can be individually formed to perfectly fit instruments and measuring equipment.

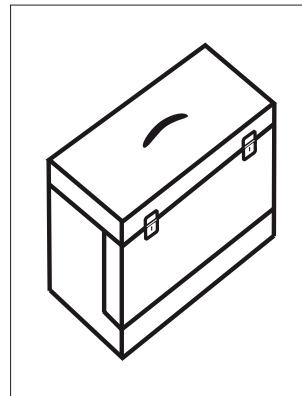

### **U** Uniport

The uniport is the perfect mix of case and box. Often preferred for measuring instruments or complex presentation uses. After opening the lid another front hatch offers even more accessibility to the contents.

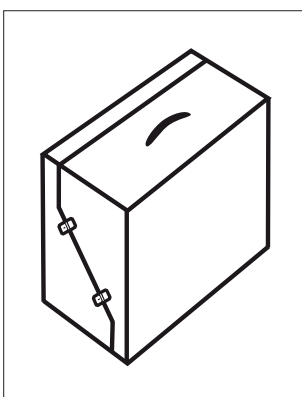

### **X** X-Case

The x-case is the answer for the podium form presentation system. With two identical V-shaped halves this becomes the optimal presentation set.

## Mobility and Handle Systems for Boxes

**B1**

Retractable handle, permanently mounted on exterior.

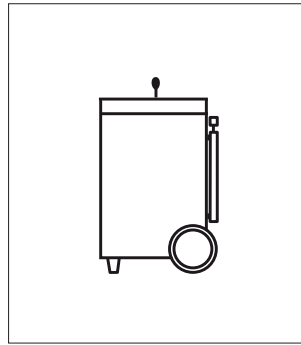
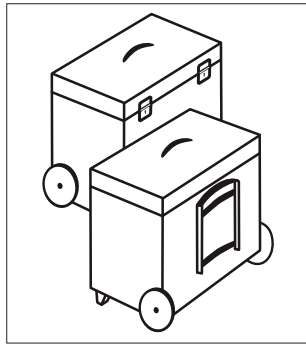

**B1**

Rollers 150 mm wide with rubber gripping surface for optimal comfort even on uneven grounds. Retractable handle mounted permanently on side of case.

**B2**

Retractable handle, mounted in pivoting exterior mechanism.

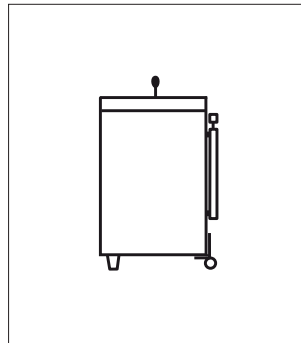
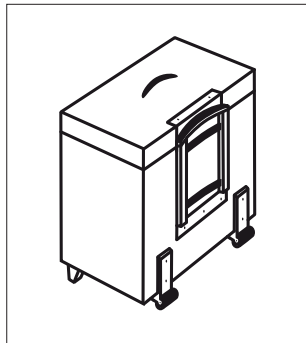

**B2**

Corner rollers 40 mm mounted on exterior

**B3**

Built-in retractable handle, permanently mounted.

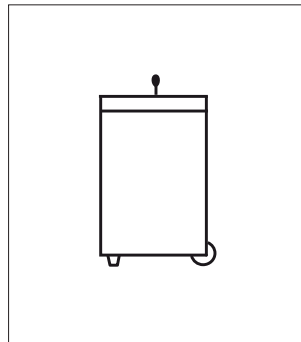
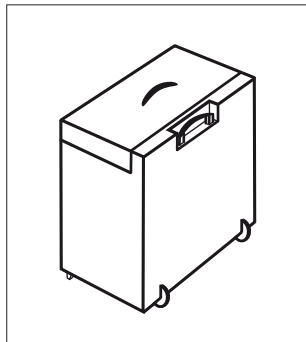

**B3**

Built-in inliner wheels. Inconspicuously integrated with smooth rolling feature.

Handle systems B1 - B3 are able to be individually combined with roller systems B1 - B3.

**B4** **B4**

Trolley, retractable handle with integrated rollers. Removable with quick release lock. Mounted on back side of case.

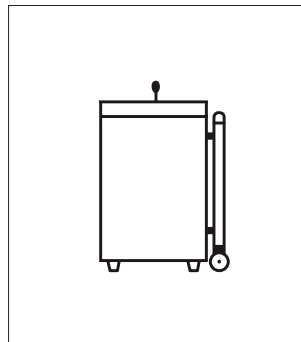
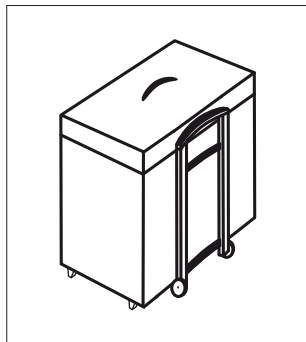

**B5** **B5**

Trolley, retractable handle with integrated rollers. Removable with quick release lock. Mounted on bottom of case.

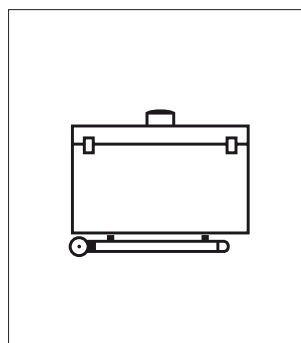
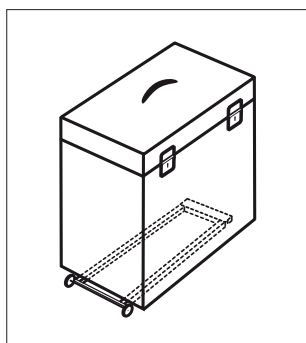

## Mobility and Handle Systems for Cases



Built-in retractable handle, permanently mounted. Due to compact construction minimal space inside the case is lost.

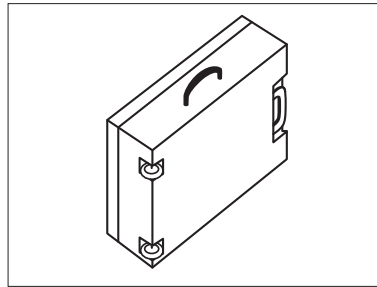

Built-in inliner wheels. Inconspicuously integrated with smooth rolling feature.



Retractable handle, permanently mounted on exterior. The affordable handle solution to retain usable space in the case.

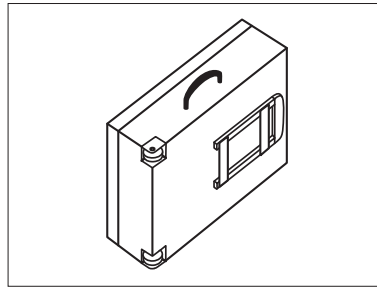

Built-in corner rollers 50 mm.



Retractable handle, permanently mounted on exterior. The affordable handle solution to retain usable space in the case.

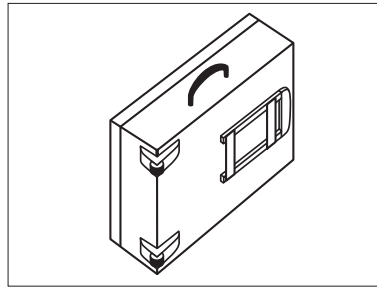

Corner rollers 40 mm.



Retractable handle, permanently mounted on exterior. The affordable handle solution to retain usable space in the case.

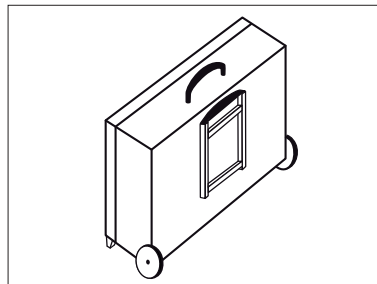

Rollers, 150 mm wide, with rubber gripping surface for optimal comfort even on uneven grounds.



Retractable handle, permanently mounted on exterior. The affordable handle solution to retain usable space in the case.

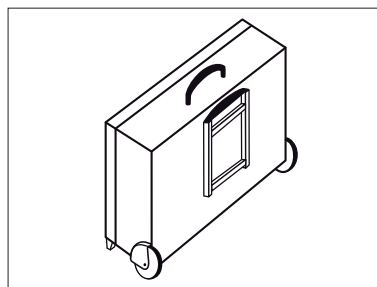

Attached rollers with "fenders"-die-cast housing, roller diameter 80 mm. Designed for use with heavy contents. Especially sturdy construction.

**Handle systems K1 and K2 are able to be individually combined with roller systems K1, K2, K4, K5 and K6.**



Trolley, retractable handle mounted on exterior. Removable with quick-release lock.

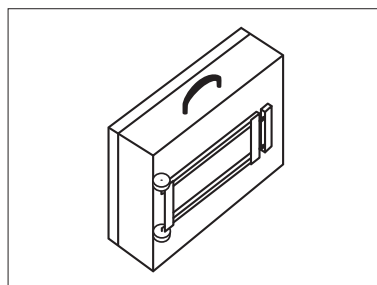

## Surfaces and Colours



### Standard, flexible or individual.

For each of the production lines we offer a wide variety of surfaces and material with standard cases. Within the framework of the designated range of surfaces, complete flexibility is possible.

With an eye for detail and your satisfaction as our goal, we'll always find the surface and colour solution that meets your every expectation.

With the understanding of the minimum quantity order, we "bend over backwards" to comply with your wishes.



### Light-weight building board

The special light-weight honeycomb panel made of polypropylene is the ideal material to save on weight with larger cases, yet remains enormously sturdy.

Light-weight building board, black



Light-weight building board, grey





## Surfaces and Colours

### Silver foils / PVC foils

The high quality but affordable surface with great effectiveness in promotion an advertising. Optically there is little difference to real aluminium surface. Depending on the kind of surface it can be ideal for printing your CI on it.



Silver foil  
Brushed effect



Silver foil  
Diamond structure

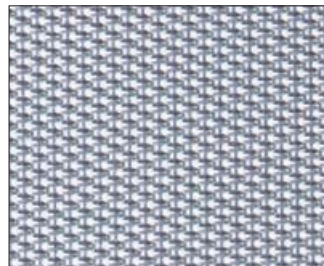

PVC foil  
Quattro, silver-grey

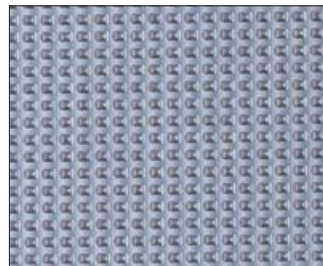

PVC foil  
Quattro, black

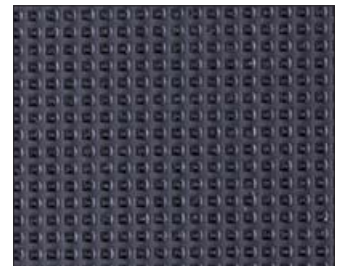

### Aluminium

The special, elegant and high quality variation. This case will quickly become an indispensable part of your everyday accessories.



Aluminium plate  
smooth, anodized

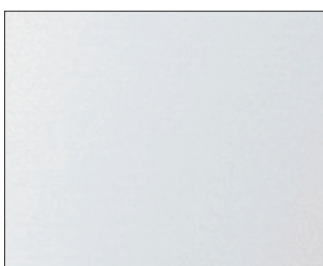

Aluminium plate  
corrugated, anodized



Aluminium plate  
stucco, natural



## Surfaces and colours

### Laminate

Durable, attractive cases thanks to multi-layers of laminated surfaces. Perfect for robust, demanding jobs. Long-lasting and resistant to acids, oil and heat due to the use of multi-layered epoxy resin materials.



Mandarin, Red No. 431



Mandarin, Yellow No. 860



Mandarin, Green No. 450



Mandarin, Blue No. 851



Mandarin, Grey No. 472



Mandarin, Black No. 421



Mandarin, Anthracite No. 551

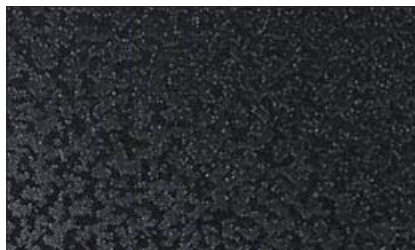

Oslo, Black No. 421

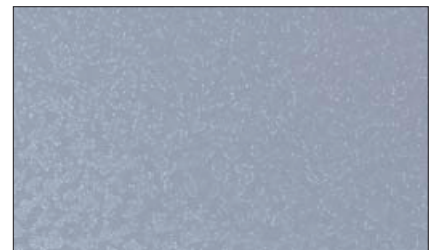

Oslo, Silver-grey No. 475

### Polystyrene Construction Line PRIMO

Especially for the PRIMO production line: 2 mm thick polystyrene material with fine texture. Especially suitable for multi-coloured designs, heightening the individuality of your case.

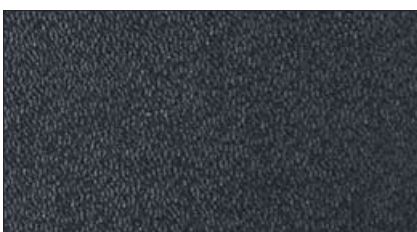

Polystyrene, Black

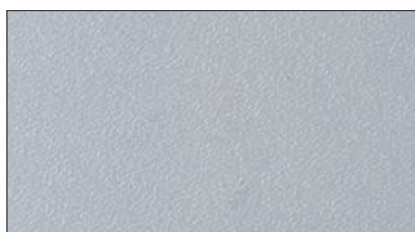

Polystyrene, Silver-grey

---

## Interior Design

The coordinated inner features turn a case into a professional instrument for daily use. Smooth foam protects valuable content. We have precisely the right material for every possible requirement.

For optimal application in cases only two quality materials are used: Soft foam (EF) and rigid foam (PZ/LD).

### Soft foam

Pliable foam from Polyurethane (PU) with a soft feel, e.g. nap foam is ideal for case padding and is relatively affordable in bulk purchase.

The colours range increment from light to dark-grey. Standard thicknesses are 20 / 30 / 40 mm.

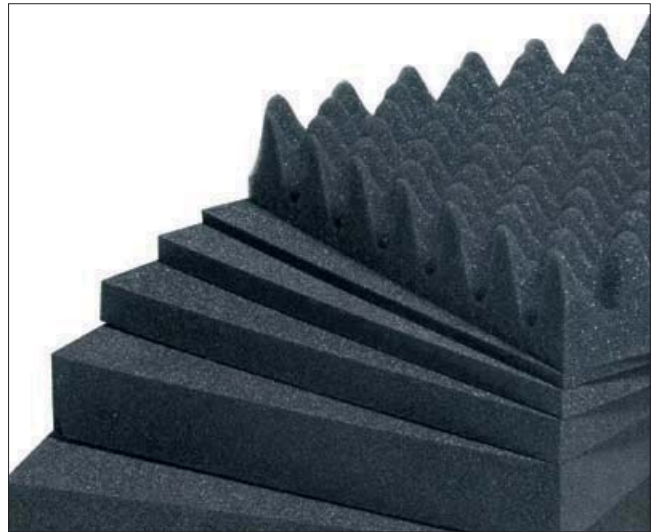

---

### Rigid foam

The dense cellular, fine-poured foam made of plastazote (PZ) is ideal in presentation solutions because of its firmness.

By use of water-jet, milling or die-cutting, all of your products will rest securely in an exactly cut form. Colours in black, light-grey and light-blue offer many possibilities.

Standard PZ thicknesses are: 5 / 10 / 15 / 20 / 30 / 40 / 50 / 60 mm. Additional thickness can be attained by laminating layers of foam.

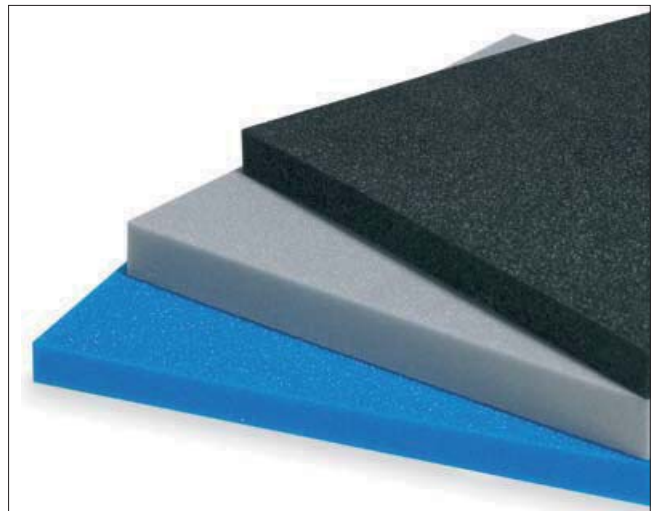

---

### Notched foam

This specialised foam worked in panels with pre-cut notches is the perfect solution for variable dividers in cases. Increments of 15 mm allow you to design the compartments of your case to your individual needs. If necessary the size and depth of increments can be altered.



## Processing of Foam

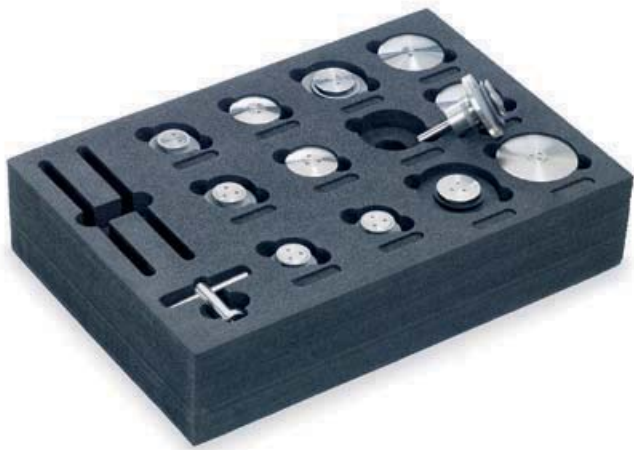

### Milling

Complete 3-dimensionality of the cut-outs can be achieved in one operation. Rigid foam pads are the inserts' basic material. The individual profile of the cut-outs is computer programmed and guided. Even different heights and depths are no problem within one cut-out. The programmed form can be identically repeated at any time.

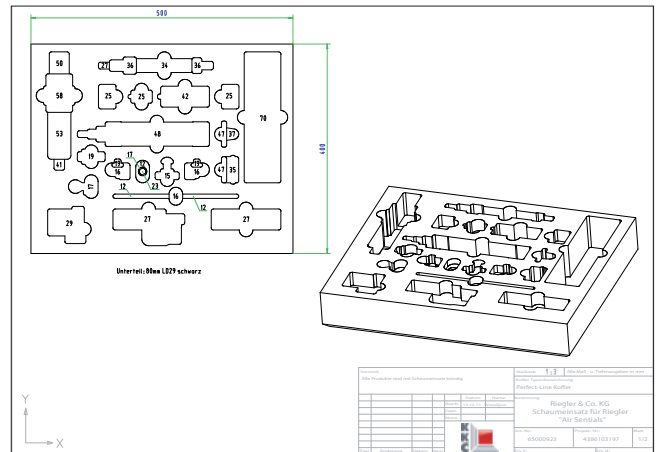

Several incoming parts simulate the contour of the cut-outs. With the help of CAD programs the profile of all cut-outs will be identified. The ideal order of products or rather of cut-outs results from the CAD drawing.

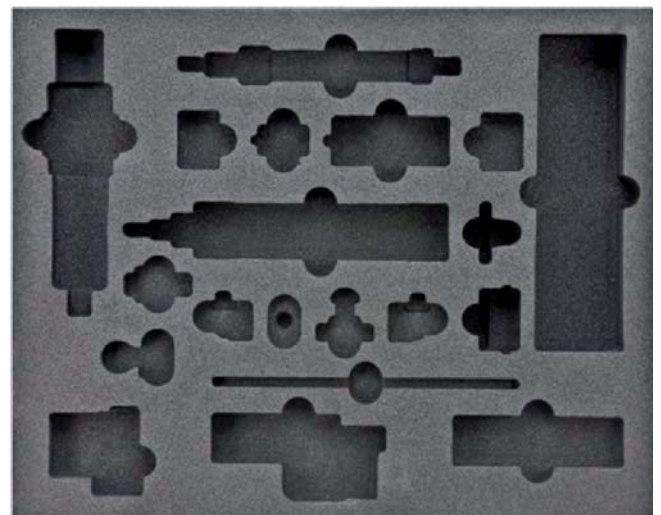

The CNC-milling machine carves out the profile of the foam according to the drawing. This form of insert can be identically repeated in bulk quantities. Quality remains the same.

## Technology and Processing

### Laser Engraving

The used machines make the direct labelling of the foams' surfaces possible. With this you will get the perfect product presentation as basis for a successful selling process.



Two-coloured milled foam insert



### Water-Jet Cutting

Absolute precision is achieved with water-jet cutting. Sharp, gentle or round profiles are perfectly formed. The different heights are achieved by craftsmanship.



### Form Cutting

The professional and of good value processing of flexible foam. Additional refining can be applied with flocking.



## Deep Recessed Inserts



Deep recessed inserts are an affordable alternative to foam. Despite the one-time machine set-up costs the unit costs can be kept low. When stability is needed for heavy tools or easy cleaning is required for presentation, this is the answer.

### Deep recessed inserts with smooth PVC

Deep recessed inserts of smooth, indelible PVC are the perfect solution when cleaning is necessary for medical instruments. Affordable, thin dividers are just the right thing for promotional and advertisement occasions. Thicker dividers are available for technical needs.

The standard colour is black; coloured and transparent inserts with textured or smooth surfaces are as well available.



### Flocked plastic deep recessed inserts

To give special value to your products, present them on a velvet-textured surface with a flocked finish. Our black and coloured material which is always in stock guarantees an elegant result.



---

## Compartment Divider Systems

Dividers come in handy when a large area needs to be compartmentalized.

### Permanently mounted dividers

Permanently mounted dividers prove their worth when the compartments are constantly in use, especially in the professional field. They are indispensable for use as a standard tool case for larger products.



---

### Variable Compartments

Variable compartments can be achieved with simply re-inserting the dividers into the pre-cut increments. This adjustable system ensures safe transport of the case's content. They could be laminated with foam for a safer transport.



## Compartment Divider Systems



### Notch-Insert System

Opposite case walls are lined with notch-insert rigid foam panels, fiber board or deep inserts. According to the needed size of compartments flexible dividers are easily slid into place.



### Organisation Trays

Plastic assortment trays to achieve individual and perfect order for those small items in the case.

Four large coloured trays come as standard accessories. Customized colours, depending on the quantity, allow for limitless organization possibilities.

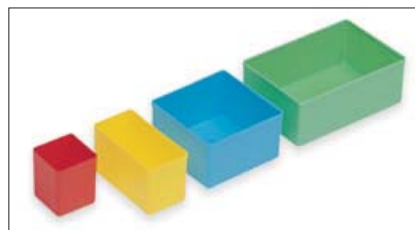

### Specialised Trays

Specialised trays are indispensable for categorizing, organizing and establishing a clear overview for presenting all those small items. There are no limits to the variations.





---

## Panels and Mounting Boards

Panels and mounting boards for safe and protected separation of products in both upper and lower parts of the case. Documents and small items all have their place.

### Lid Panel

The lid panel ensures that all the contents remain neatly and safely in place during transport.



---

### Organisation Panel

This panel acts not only to ensure that the contents remain in place but affords a diversity of possibilities for storage of documents and other items.



---

### Tool Panel

Replaceable tool panel - able to be used in the lid as a storage and protection panel. Either single or double-sided with elastic holding bands or pouches and pockets for tools and work material. Remove the panels and you have a universal case.



## Panels and Mounting Boards



### Cover Panel

A transparent cover panel serves as optimal protection of your products and gives a clear view of your presentation.



### Attaché Insert / Lid Panel

Attaché insert in lid of business case for papers, writing utensils and documents. You determine your organization system according to what material you choose. Everything you need is at a glance.



## Panels and Mounting Boards

### Mounting and Front Boards

For measuring, electrical- or electronic technique the placement and mounting of instruments in case is essential. The case assembly and front board have been designed just for this purpose. The front boards are held in place by sliding nuts as well as angle extrusions with pop rivet nuts.



### Electrical Cabling and Assembly

Electrical cabling and assembly can be expertly carried out according to given plans and parts lists due to complete VDE 0100 certified electrical cabling unit. Instruments and functional parts can be integrated in the printed front board of case.



---

## Drawer Cabinets



Drawers are the professional solution for transporting and presenting small products, product parts or product groups.

A successful presentation is achieved by means of high quality drawer features such as foam inserts, deep recessed inserts or completely tailor-made solutions.



---

### Drawer Cabinets on Rollers

As an added feature we can mount your specialized drawer cabinet on rollers. When size and weight of the drawer cabinet exceed carrying convenience, our roller system is mounted which enhances effortless mobility of the complete cabinet as, for example, a brochure display.

---

## Drawer Cabinets

### Removable Drawers

Not only can these drawers be extended for ideal viewing, but they are easily removed and replaced. Sophisticated and elegant features as well as custom coating bring out the quality of your product.



---

### Drawers with Covers

For special requirements the drawers can be fitted with covers. This ensures a tight hold for content or serves as a display cover should there be a need for keeping certain items out of immediate view.

The drawer covers can be made of the same material as the drawer itself, if desired.



---

### Foam Drawer

The foam drawers are advantageous due to the light-weight rigid foam material reinforced with a bottom panel. Ideal for small and light-weight products.

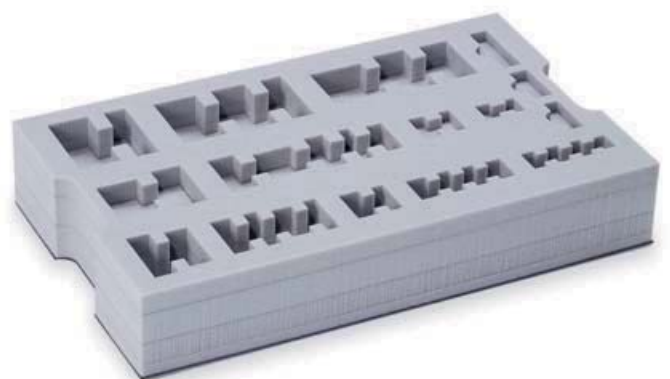

## ... for every case: Individualising with CI and Promotion.

Use the surface of your case of box to promote your company:

Depending on the choice of surface we offer a wide range of possibilities for your "message", your CI or your market presence to "catch the eye" of your potential customer.

Refine "your" case.

Show your colours; show your competence through identification to your firm. Promote and strengthen your new line of products.

Use your case to penetrate the market.

Labels / Transfer Labels



Screen-printing - Direct Printing



Laser Engraving (only on aluminium plate)



Embossing (only on aluminium plate)



Digital Print, multi-coloured



Labels / Dome Labels







**KKC cases GmbH**

Tailor-made Cases and Carrying Cases  
Schröttinghauser Straße 20  
32351 Stemwede-Levern

Tel. +49 (0)5745.92050  
Fax +49 (0)5745.920529

info@kkc-cases.de  
www.kkc-cases.de

